



SEA[®]

Sistemi Elettronici
di Apertura Porte e Cancelli
International registered trademark n. 804888

CE

Italiano

English

Français

Espanol

Deutsch

ATTUATORE OLEODINAMICO PER CANCELLI A BATTENTE
HYDRAULIC OPERATOR FOR SWING GATE
ACTUATEUR HYDRAULIQUE POUR PORTAIL À BATTANTS
ACTUADOR OLEODINAMICO PARA CANCELAS ABATIBLES
ÖLDRUCKANTRIEB FÜR SCHWINGTORE

HALF TANK
MINI TANK



MANUALE D'INSTALLAZIONE
ed informazioni sulla sicurezza

INSTALLATION MANUAL
and Security Information

FEATURES AND SPECIFICATIONS

The **HALF TANK 270**, **HALF TANK 390** and **MINI TANK** are high quality hydraulic operators for residential and condominium use with leaf length up to respectively 6m, 7 m and 3 m.

Available in the following versions:

AC (*with lock in opening and closing*)

SC (*with lock only in closing*)

SA (*with lock only in opening*)

SB (*without lock*)

Hydraulic locking is guaranteed on gates with length up to 1.80 m with the Half Tank 270 and Mini Tank operators while for lengths up to 2.20 m use the Half Tank 390. An electric lock should be used for leaves (in all versions) exceeding those lengths.

The Half Tank 270-390 and Mini Tank are supplied with by-pass valves for the power regulation in both opening and closing. Electronic adjustable slow down in opening and closing with control board. For the European laws and directives actually in force it is strongly recommended to use the Safety Gate (device for the reading of the gate position), for reverse in case of obstacle.

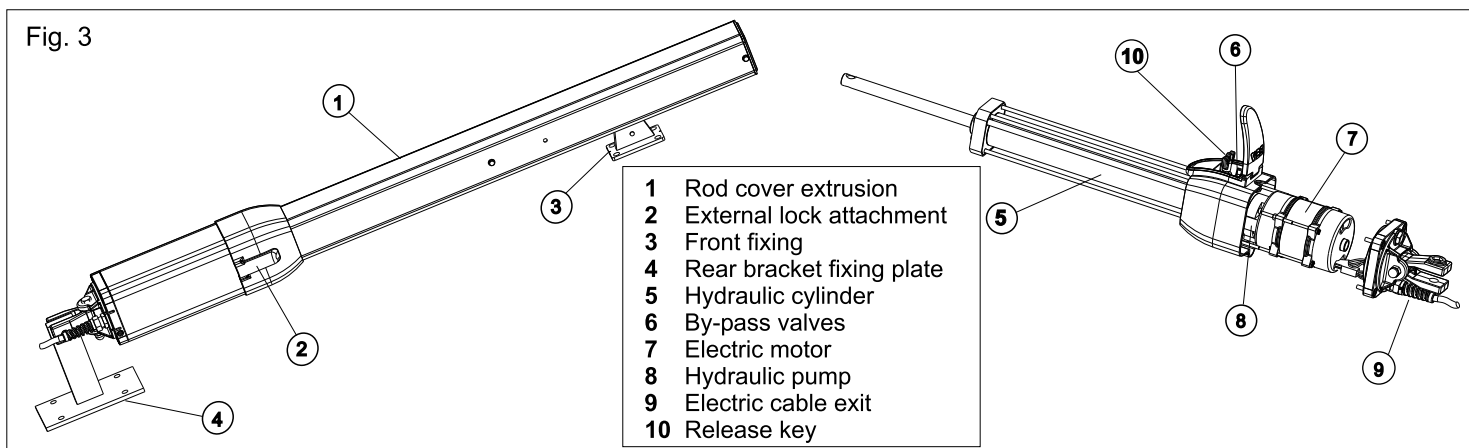
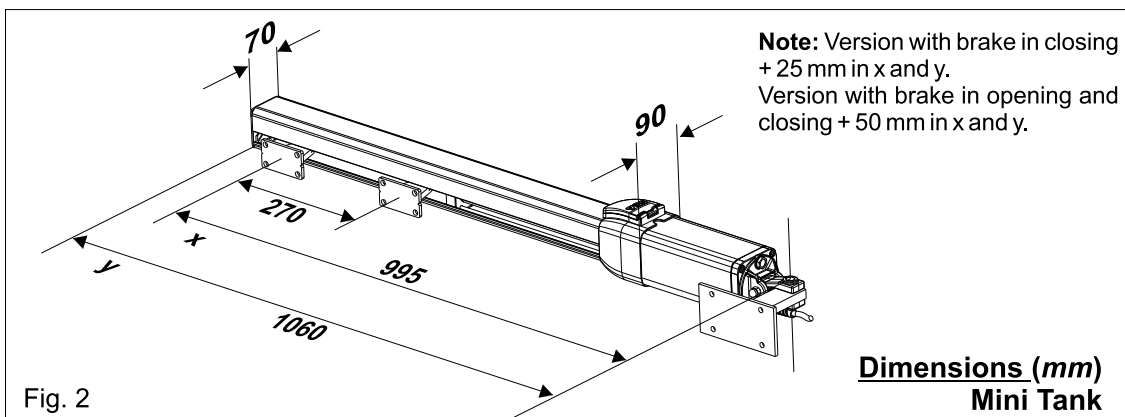
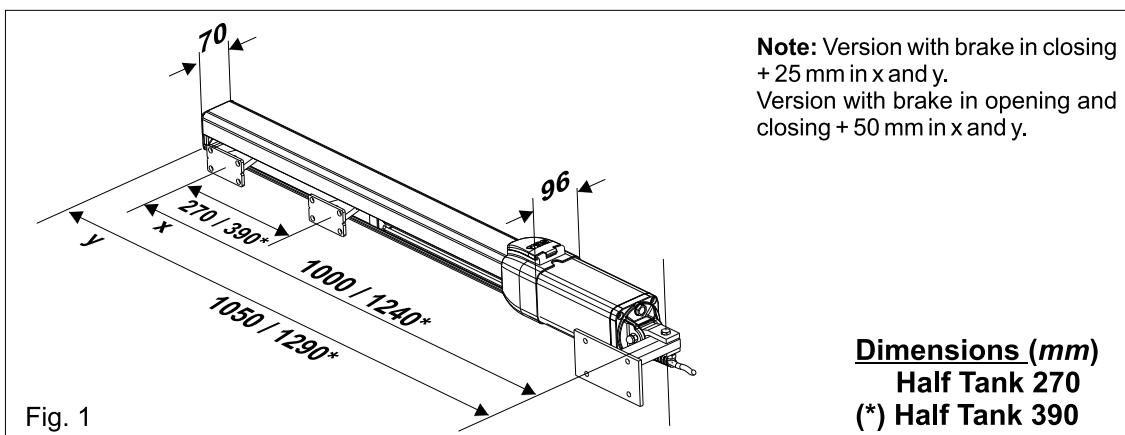



TECHNICAL FEATURES	HALF TANK 270 (230V)	HALF TANK 390 (230V)	HALF TANK 270 (120V)	HALF TANK 390 (120V)
Power supply	230 V (±5%) 50/60 Hz		120 V (±5%) 50/60 Hz	
Power	220 W			
Absorbed current	1 A		2 A	
Stroke	270 mm	390 mm	270 mm	390 mm
Rod speed	1 cm/s	1,5 cm/s	1,2 cm/s	1,7 cm/s
Cycles hour (at a temp. of 20°C)	55			
Max working pressure	40bar	30bar	40bar	30bar
Operating temperatures	-40°C / +60°C			
Thermal protection	130°C			
Max Thrust	640 daN			
Capacitor	12,5µF		60µF	
Weight	11,4 kg	13,6 kg	11,4 kg	13,6 kg
Protection class	Ip55			
Max leaf length	6 m	7 m	6 m	7 m
Opening degree of the leaf	90° - 125°			

Note: The frequency of use is valid only for the first hour at 20°C room temperature.

Note: in non-automatic logic, use operators without lock.

TECHNICAL FEATURES	MINI TANK (230V)	MINI TANK (120V)	MINI TANK WHIT JOINT
Power supply	230V (±5%) 50/60 Hz	120V (±5%) 50/60 Hz	230V (±5%) 50/60 Hz
Power	180 W	240 W	180 W
Absorbed current	1 A	2,45 A	1 A
Stroke	270 mm		
Rod speed	1,5 cm/s	1,7 cm/s	1 cm/s
Cycles hour (at a temp. of 20°C)	40		
Max working pressure	30 bar		
Operating temperatures	-40°C / +60°C		
Thermal protection	130°C		
Max Thrust	250 daN		
Capacitor	6,3 µF	60 µF	6,3 µF
Weight	10 kg		
Protection class	Ip55		
Max leaf length	3 m		
Opening degree of the leaf	90° - 110°		

Note: The frequency of use is valid only for the first hour at 20°C room temperature.

Note: in non-automatic logic, use operators without lock.

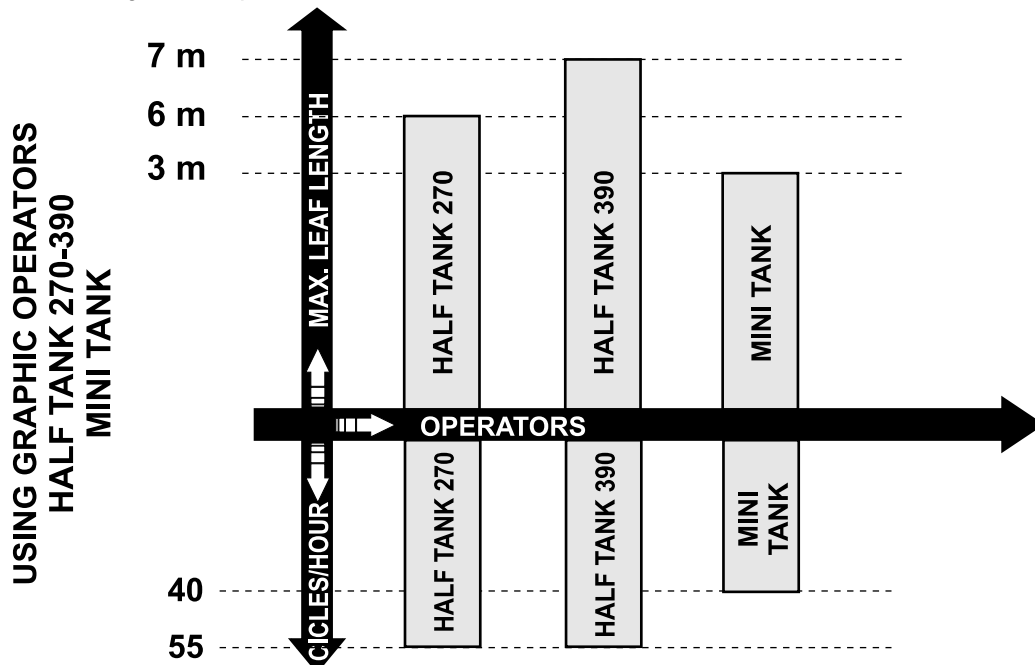



HALF TANK
MINI TANK

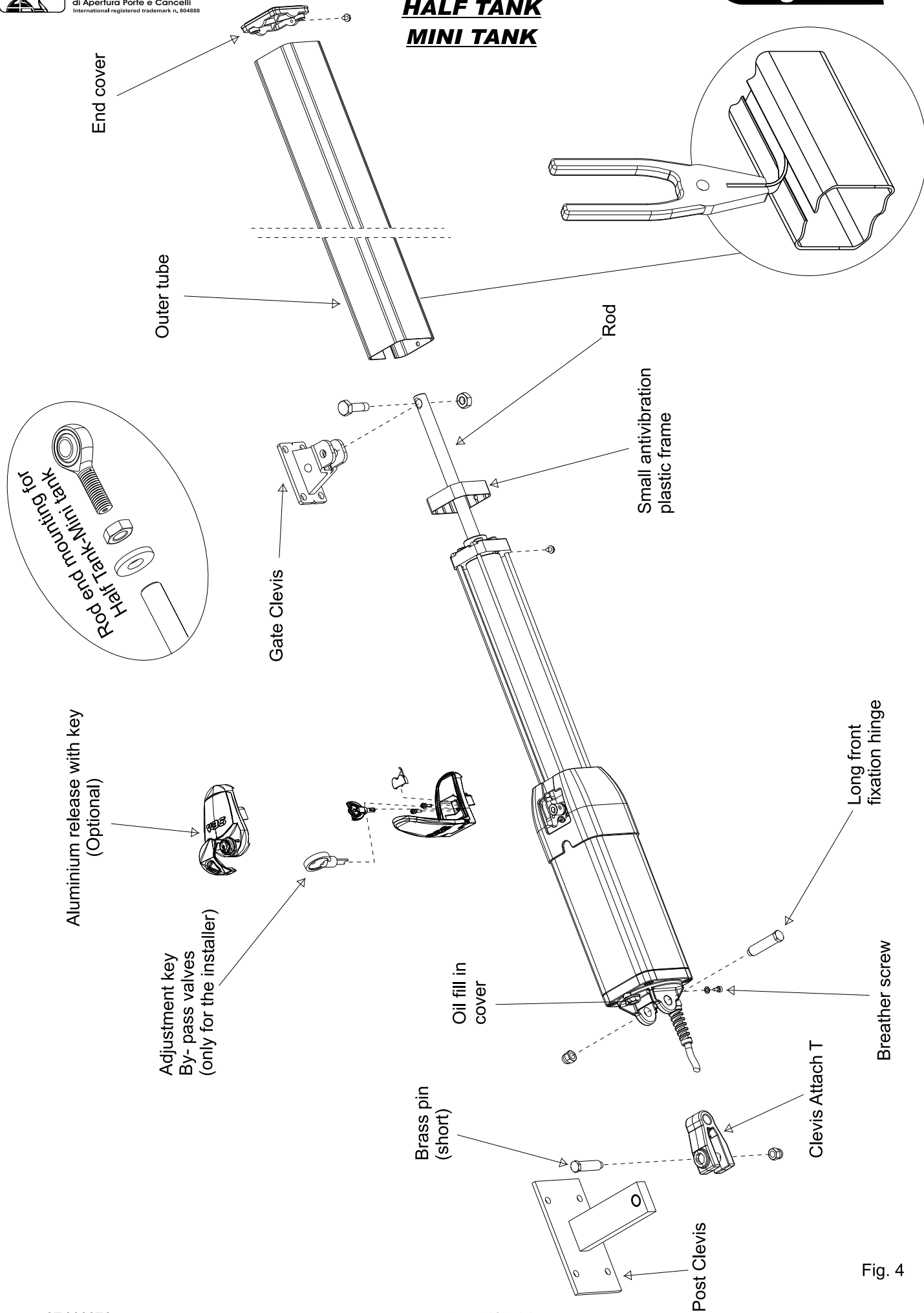

Fig. 4

STANDARD INSTALLATION

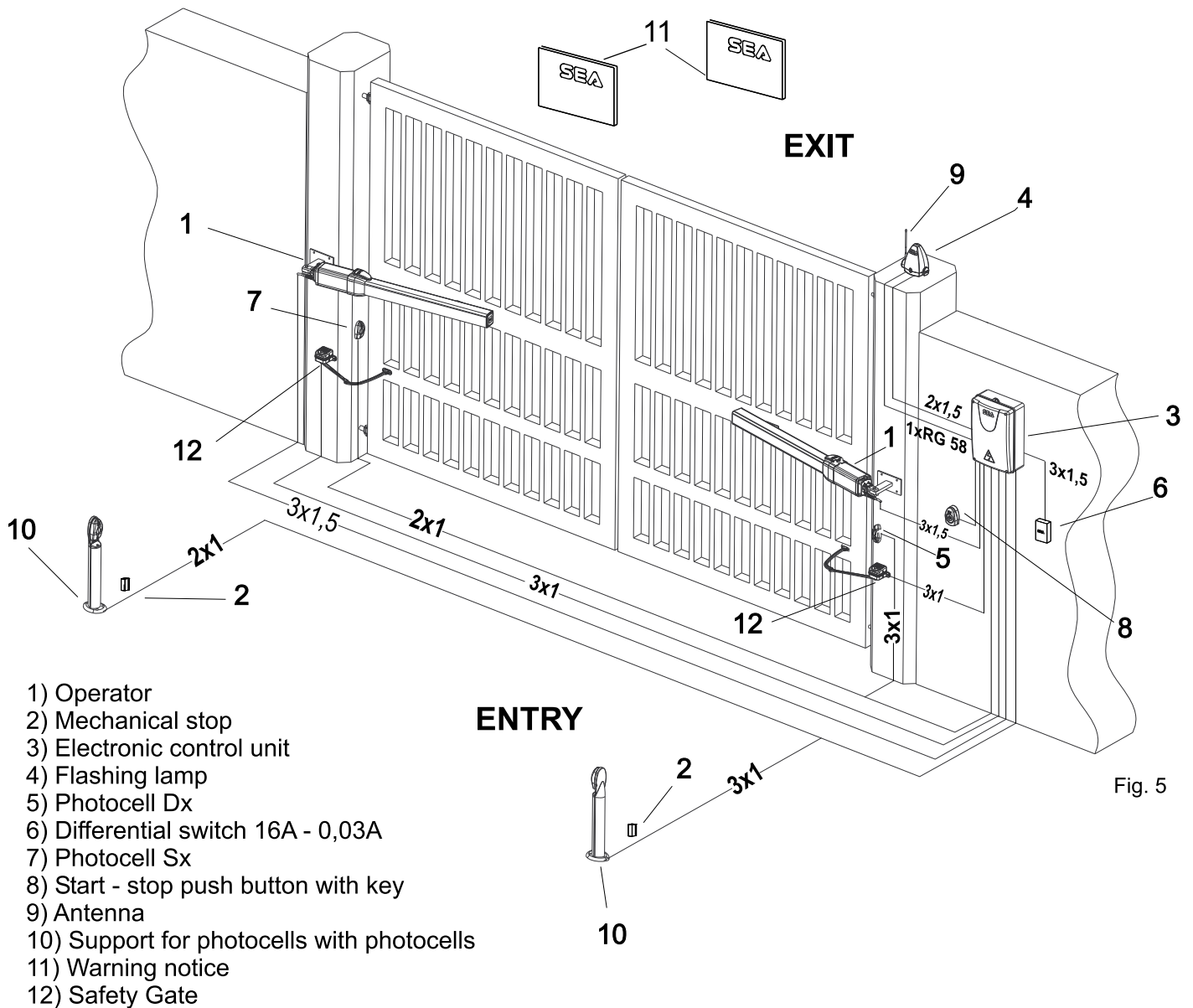
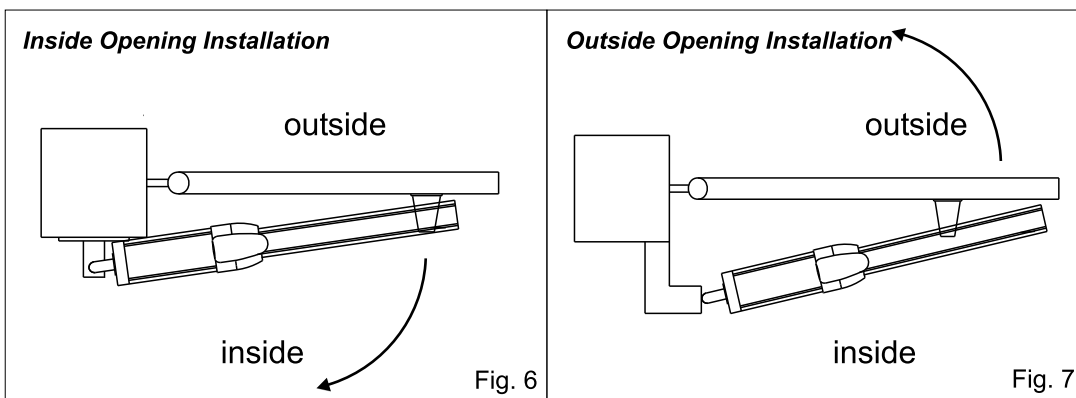

Fig. 5

INSTALLATION TYPE

It is possible to install the operators with the opening towards the inside (Fig. 6) or towards the outside (Fig. 7).



Install the operator always on the inside of the property

INSIDE OPENING INSTALLATION

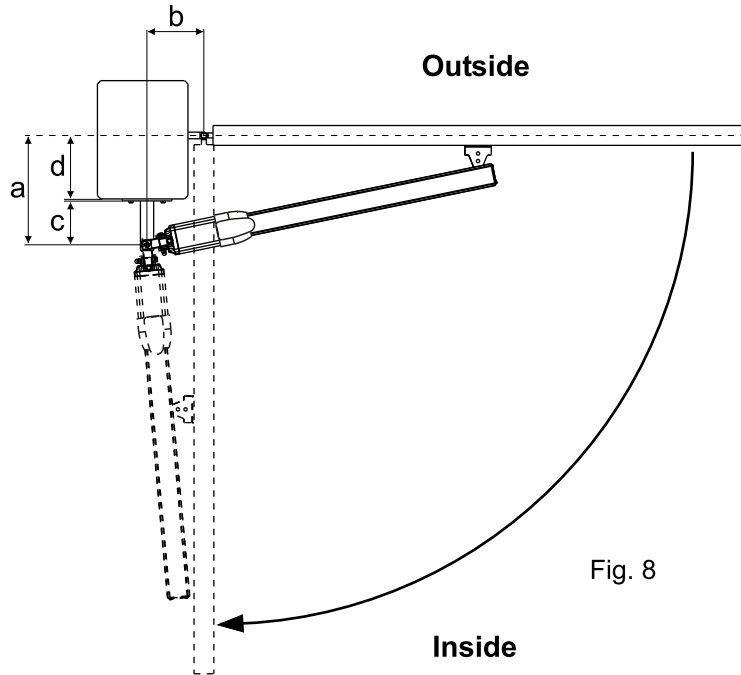

HALF TANK 270

Total stroke 270 mm - max suggested stroke 250 mm.

a (mm)	b (mm)	d _{max} (mm)	Max Opening Angle	Max stroke (mm)	Stroke for 90°(mm)
100	115	50	110°	250	215
100	150	50	90°	250	
105	110	55	110°	245	215
105	145	55	90°	250	
120	105	70	106°	250	225
120	130	70	90°	250	
125	125	75	90°	250	
140	95	90	100°	250	235
140	110	90	90°	250	
145	95	95	100°	255	242
145	105	95	90°	250	
150	100	100	90°	250	
155	85	105	96°	250	242
160	90	110	90°	253	
170	75	120	92°	250	
180	65	130	92°	250	

To obtain 110° with d > 55 mm it is necessary to make a niche in the gate.
To obtain 125° with d > 55 mm it is necessary to make a niche in the gate.

HALF TANK 390

Total stroke 390 mm - max. recommended stroke 370 mm.

a (mm)	b (mm)	d _{max} (mm)	Max Opening Angle	Max stroke (mm)	Stroke for 90°(mm)
125	170	75	125°	368	295
130	170	80	125°	372	300
140	235	90	90°	370	
145	165	95	120°	372	310
145	230	95	90°	370	
160	210	110	90°	370	
175	195	120	90°	370	
185	145	130	110°	370	330
185	190	130	90°	370	
195	140	140	110°	371	355
195	175	140	90°	370	
240	110	185	100°	370	355
240	125	185	90°	370	
250	105	195	95°	370	360
250	115	195	90°	370	
260	95	205	95°	369	365
260	100	205	90°	370	
270	90	215	90°	370	
280	80	230	90°	370	
295	65	245	90°	369	

MINI TANK

Total stroke 270 mm - max suggested stroke 250 mm.

a (mm)	b (mm)	d _{max} (mm)	Max Opening Angle	Max stroke (mm)	Stroke for 90°(mm)
100	115	50	110°	250	215
100	150	50	90°	250	
105	110	55	110°	246	215
105	145	55	90°	250	
120	105	70	105°	249	225
120	130	70	90°	250	
125	125	75	90°	250	
140	95	90	100°	250	235
140	110	90	90°	250	
145	95	95	100°	255	240
145	105	95	90°	250	
150	100	100	90°	250	
155	85	105	95°	249	240
160	90	110	90°	250	
170	75	120	90°	248	
180	65	130	90°	247	

OUTSIDE OPENING INSTALLATION

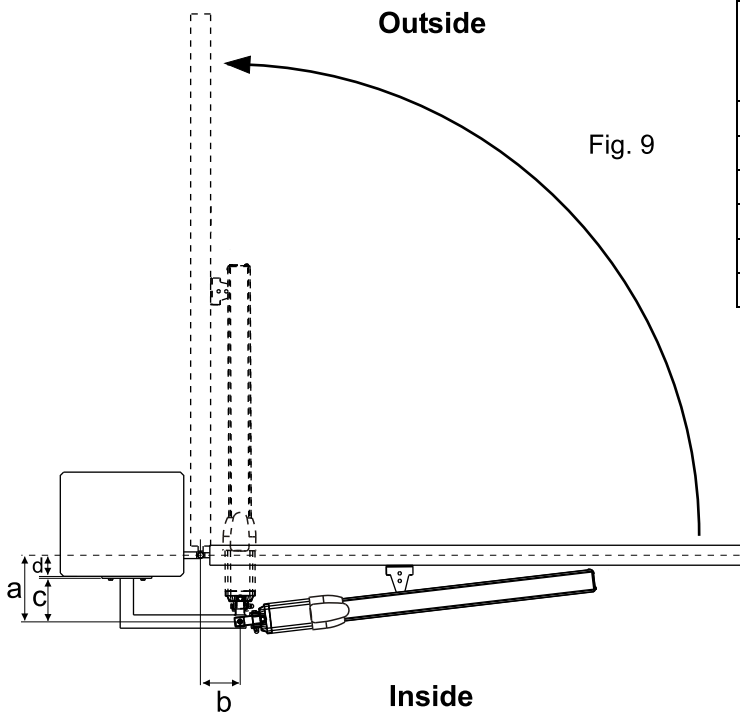

Fig. 9

HALF TANK 270 - MINI TANK

Total stroke 270 mm - max suggested stroke 250 mm

a (mm)	b (mm)	Max Opening Angle	Max stroke (mm)	Stroke for 90°(mm)
150	90	95°	250	240
160	90	90°	250	
165	80	95°	249	243
175	80	90°	250	
180	70	90°	250	
180	65	90°	241	

HALF TANK 390

Total stroke 390 mm - max. recommended stroke 370 mm

a (mm)	b (mm)	Max Opening Angle	Max stroke (mm)	Stroke for 90°(mm)
250	100	100°	356	342
255	95	95°	345	
265	95	95°	342	335
270	90	90°	330	
275	90	90°	325	
275	90	90°	319	

INSTALLATION ON MASONRY PILLARS, MAKING A NICHE

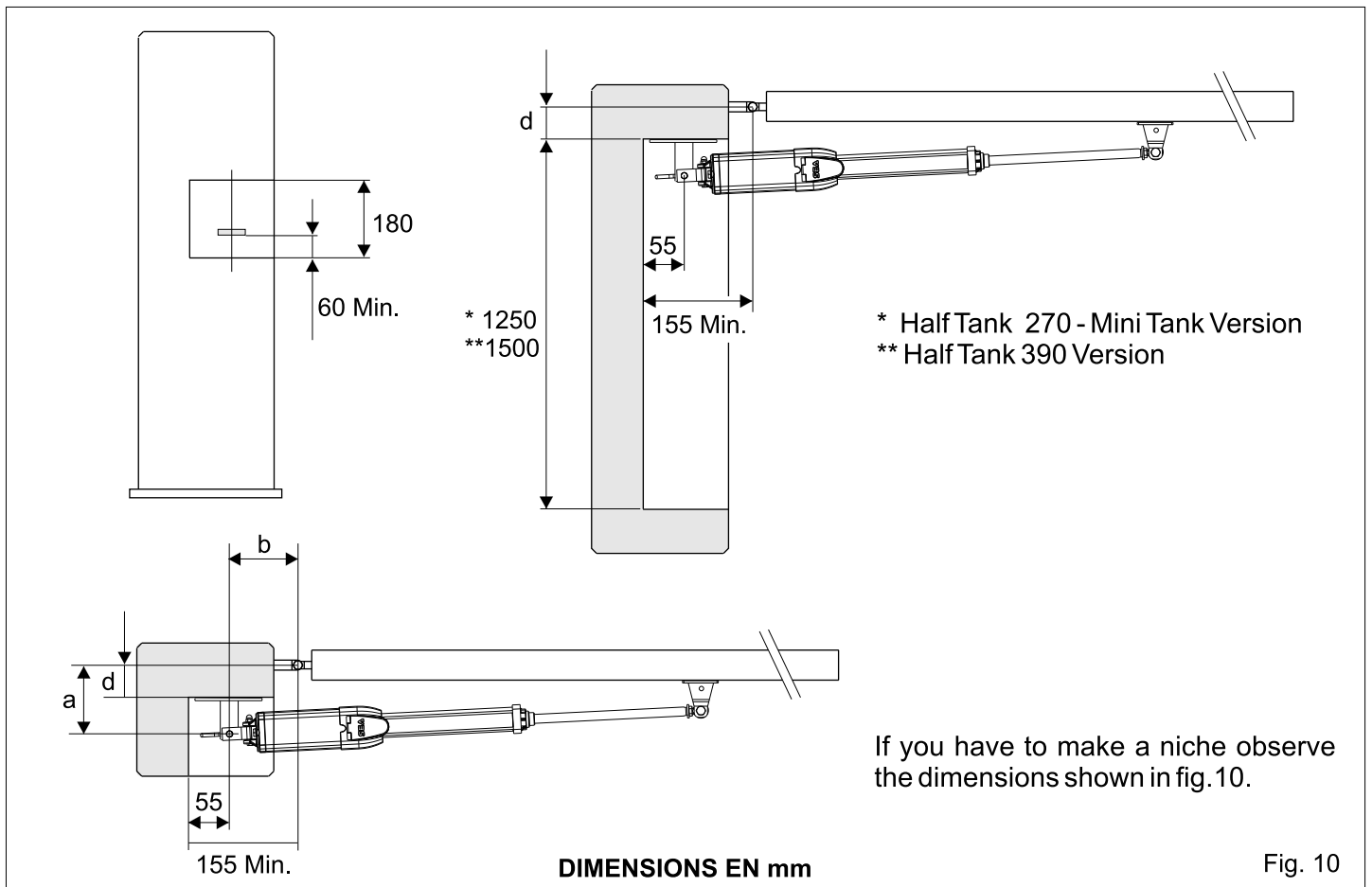

Fig. 10

OSCILLATING FORK INSTALLATION

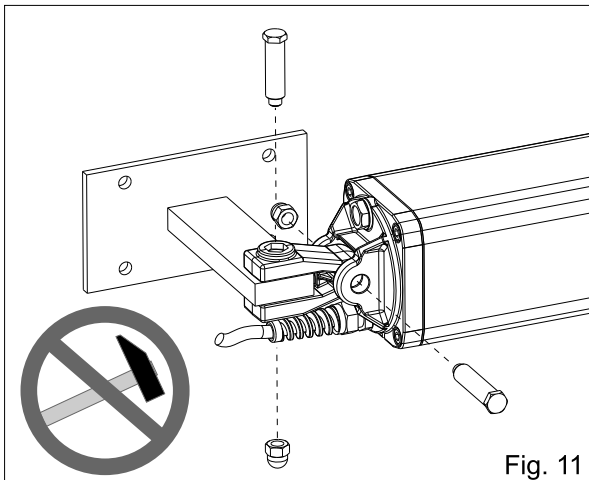

Fig. 11

PRELIMINARY

- Open the package carefully, paying attention to not lose the parts reported in fig.4
- Fix the oscillating fork as in fig.11.

Attention: do not use the hammer to insert the short brass pivot; the insertion of the pivot into the fork and bracket must be made simply by hand pressure.

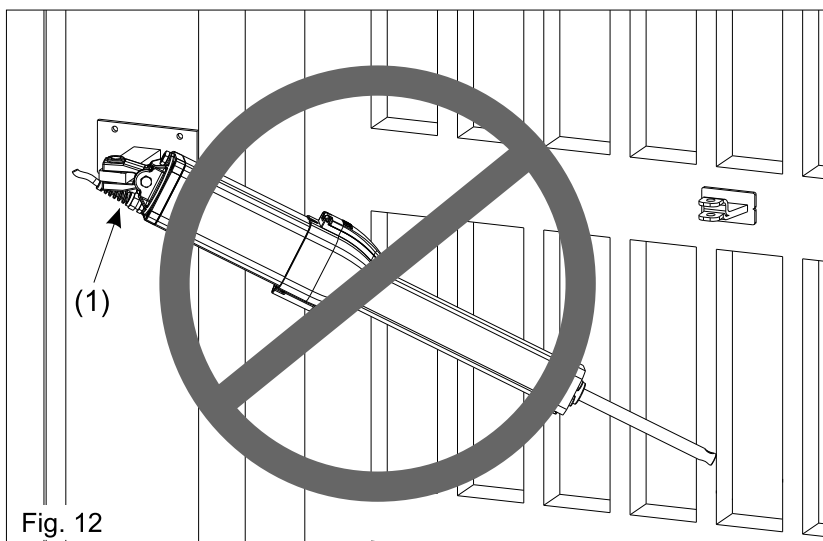

Fig. 12

Attention

Do not incline the hydraulic operator further than the allowed angle from the oscillating fork (1), could cause the braking of it (1).

BACK FIXATION MOUNTING

According to the chosen opening type (inside or outside) and according to the chosen max. rotation of the leaf (see page 21-22) the bracket must be first cut respecting the mesurment a on pag. 21-22 and than welded as in fig.14.

The support must be positioned so that the operator is in perfect horizontal position (Fig. 14, Fig.15).

Adjustable back fixation (with screw)
(Accessories on request)

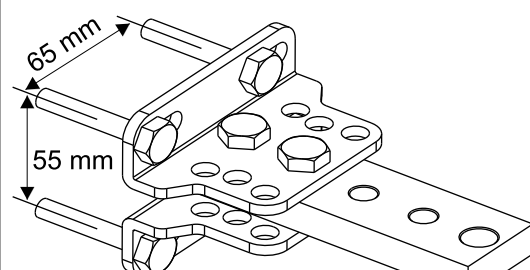

Fig. 13

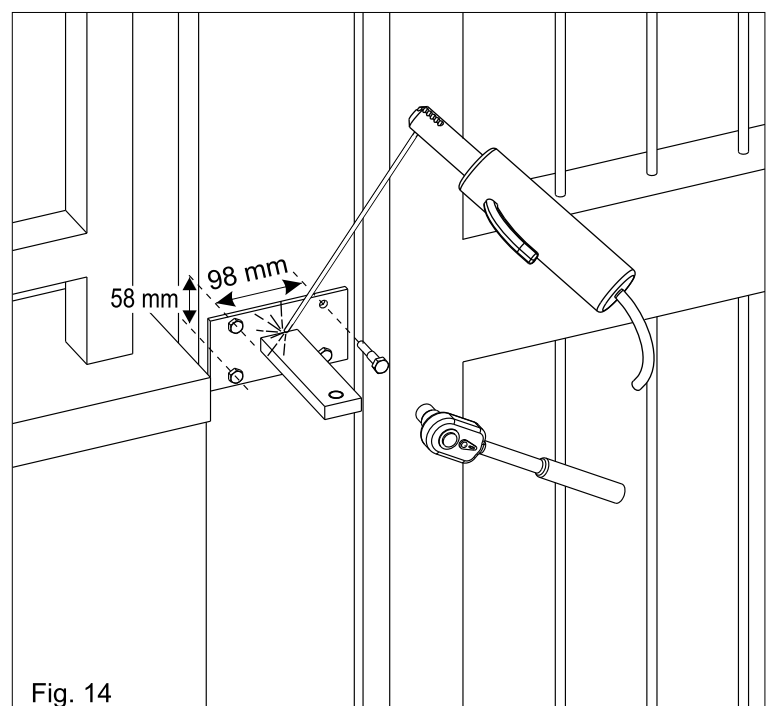

Fig. 14

POSITIONING OF THE FRONT FIXATION

Once the operator has been mounted on the back fixation close the leaf and do as follows:

- 1) Release the operator (as in Fig. 36).
- 2) Pull out completely the chromium plated rod, **afterwards bring it back about 1 cm.**
- 3) Fix the rod on the front fixation (Fig. 16).
- 4) Position the operator perfectly horizontal and mark the position of the front fixation (Fig. 15).

Attention: Avoid the welding of the front fixation to the rod of the hydraulic operator already fixed as the welding residual (squirt) could ruin the chromium -plating of the rod.

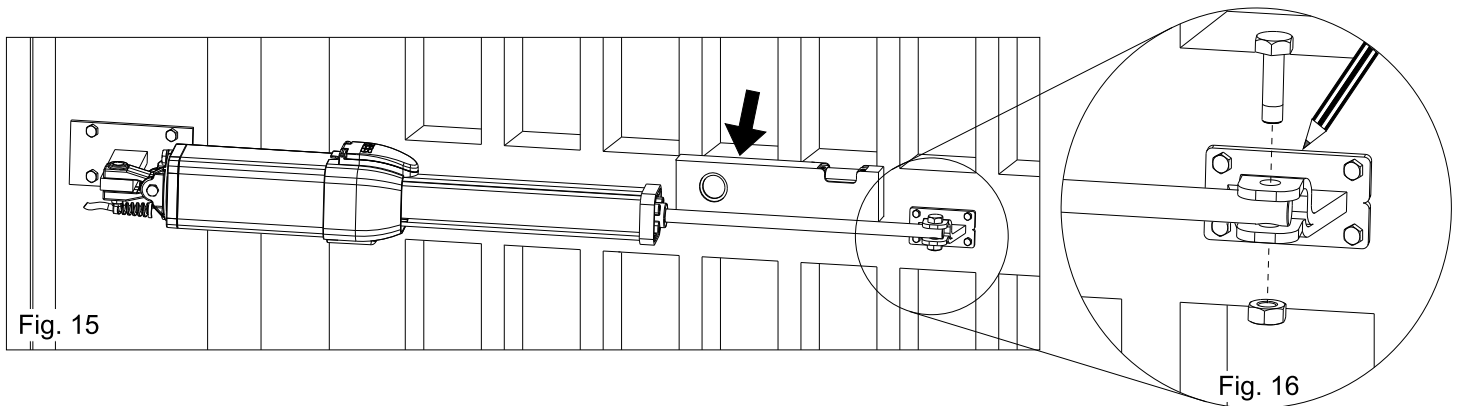

ASSEMBLING OF FRONT FIXING MINI TANK VERSION WITH JOINT (TOP)

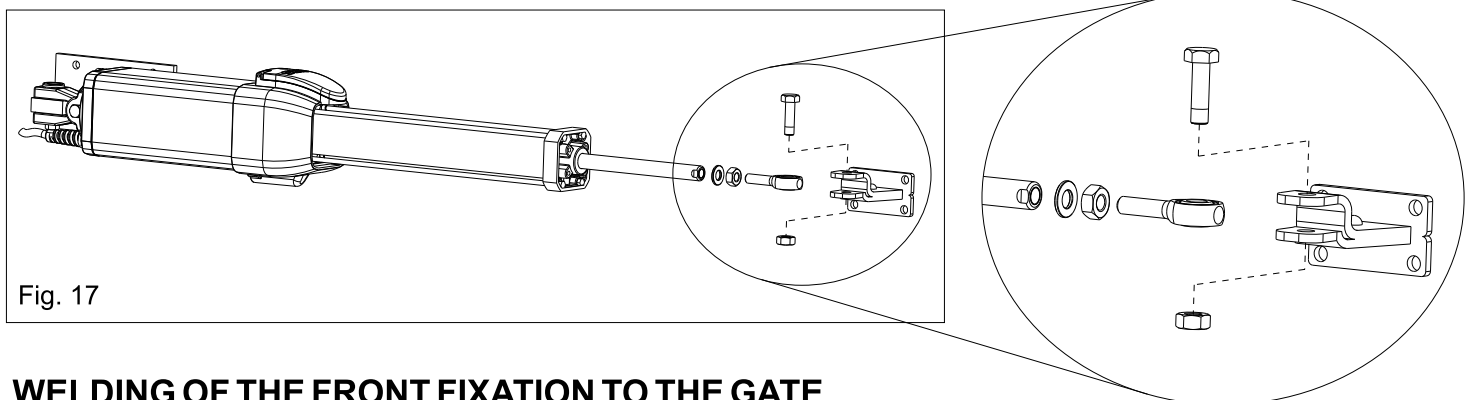

WELDING OF THE FRONT FIXATION TO THE GATE

Mount the front fixation so that it guarantees the perfectly horizontal position of the operator.

Depending on the type of the gate (wood, iron, aluminium) the front fixation can be welded or screwed.

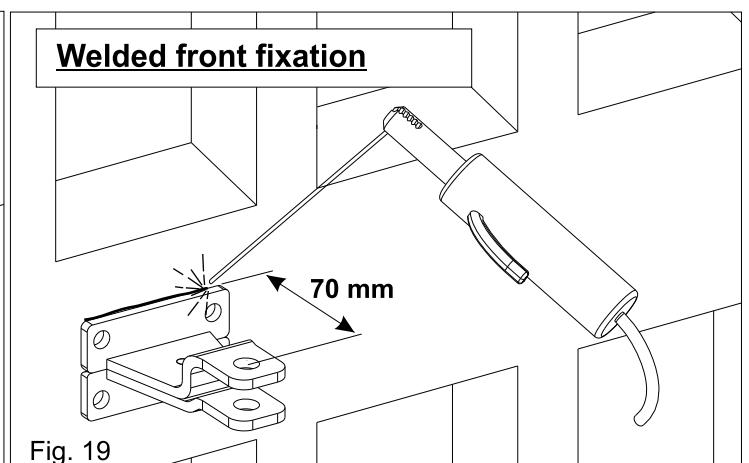
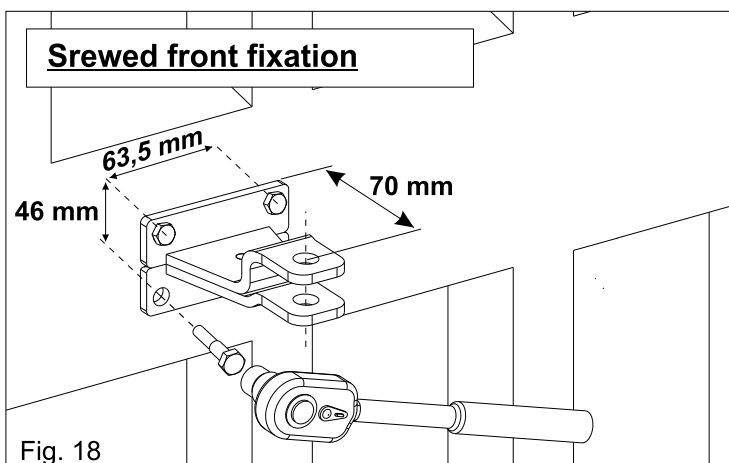

INSTALLATION OF THE HALF TANK 270-390 MECHANICAL LIMIT SWITCH STOPS (Accessories on request)

- 1) Release the unit (as in Fig. 36)
 - 2) Let the rod come out about 3/4 of its run
 - 3) Put the limit switch stops on the front flange of the unit with the two rods (of the three which are present on the stop) which are in parallel to the gate (Fig. 20)
 - 4) Fix the stop with the two included screws .
- At this point hook the rod on the front fixation
- 5) To adjust the stop in opening act on disc, and in closing on disc 2.

Attention : the mounting of the mechanical stop does not cause the reduction of the stroke

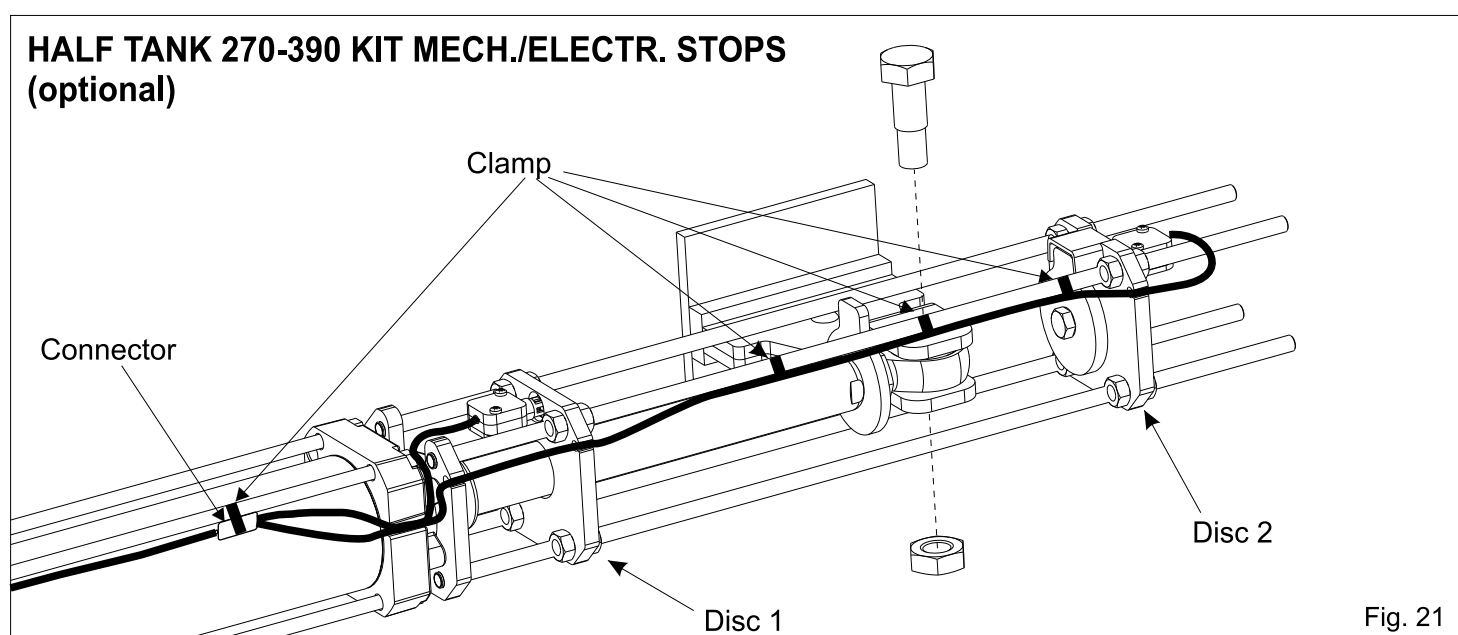
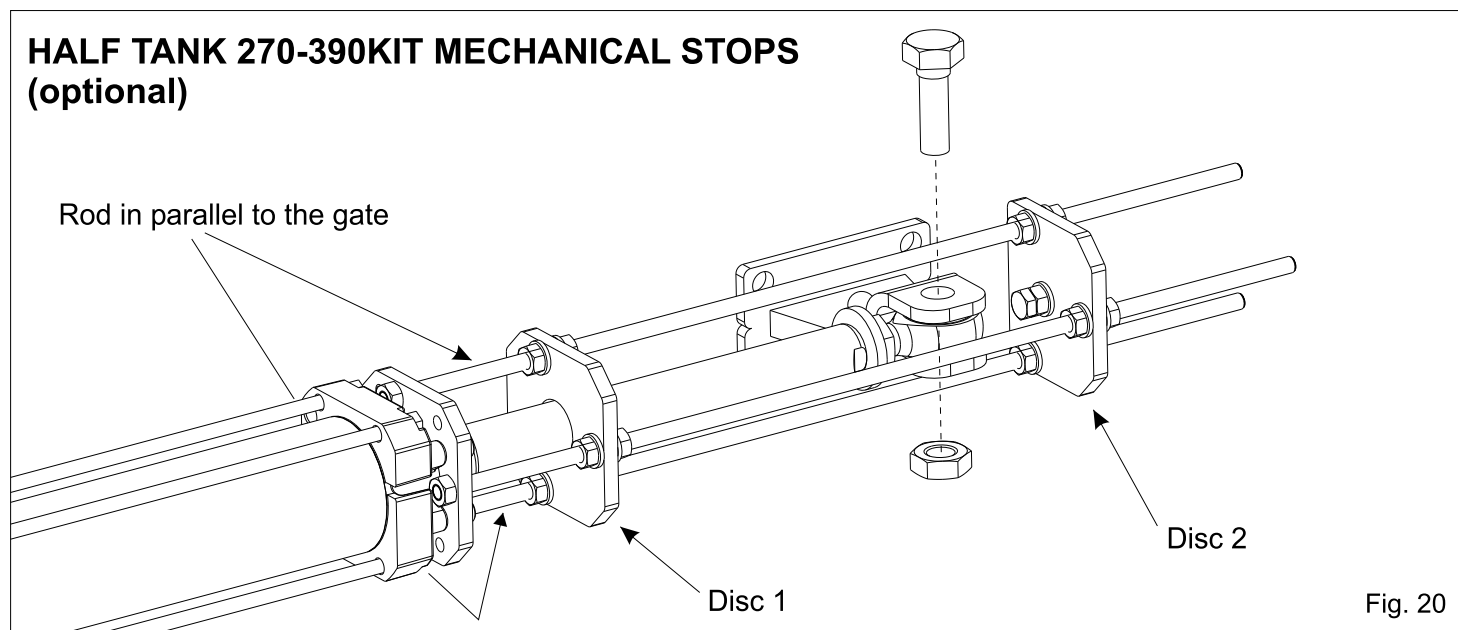

**INSTALLATION OF THE MINI TANK MECHANICAL LIMIT SWITCH STOPS
(Accessories on request)**

- Release the unit (as in Fig. 36).
- Let the rod come out about 3/4 of its run.
- Put the limit switch stops on the front flange of the unit with the two rods (of the three which are present on the stop) which are in parallel to the gate (Fig. 22).
- Fix the stop with the two included screws.
- Put the provided bush (A) into the rod.
- At this point hook the rod on the front fixation.
- To adjust the stop in opening act on disc, and in closing on disc 2.

Attention: the mounting of the mechanical stop does not cause the reduction of the stroke.

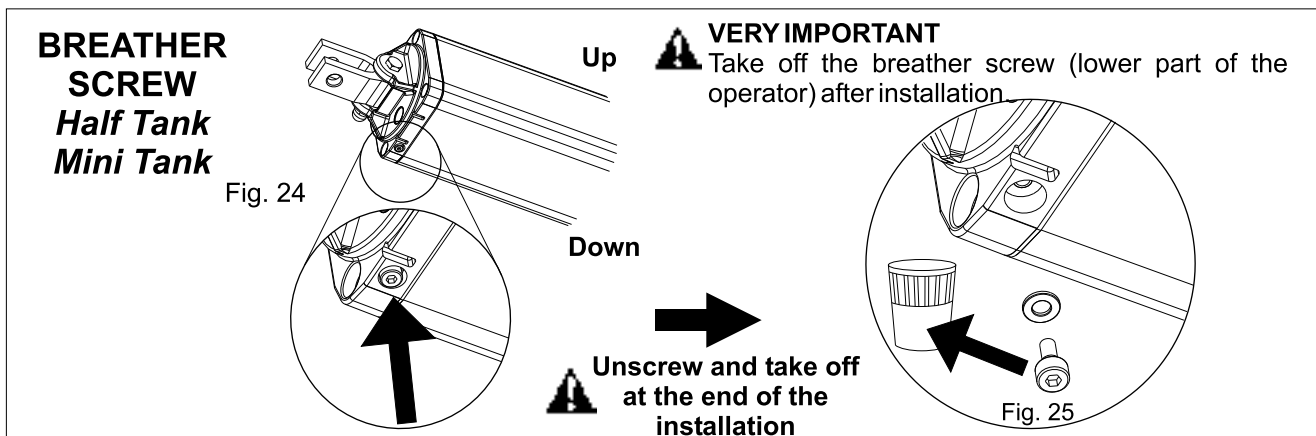
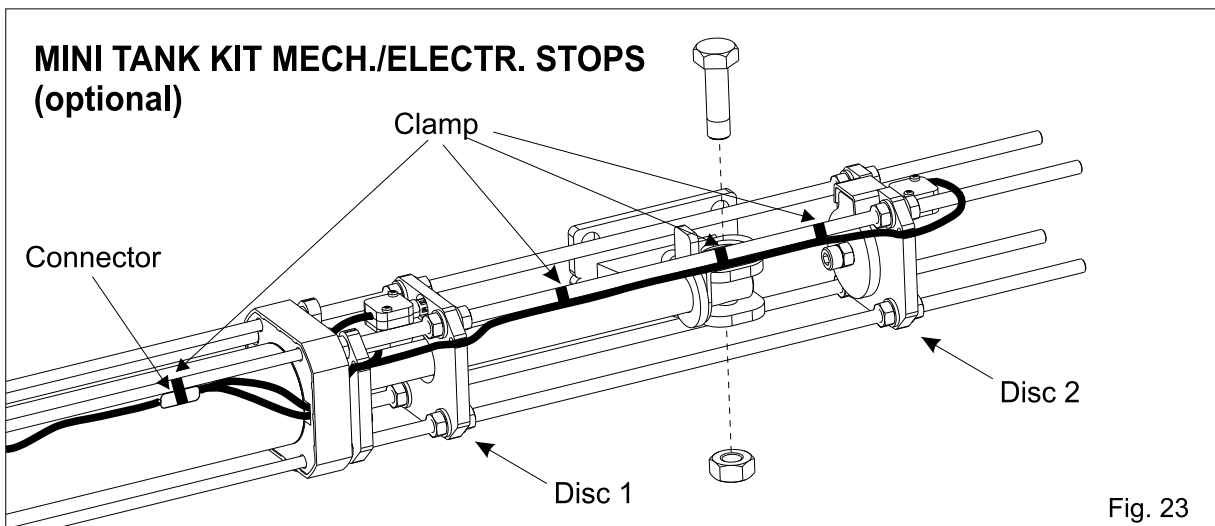
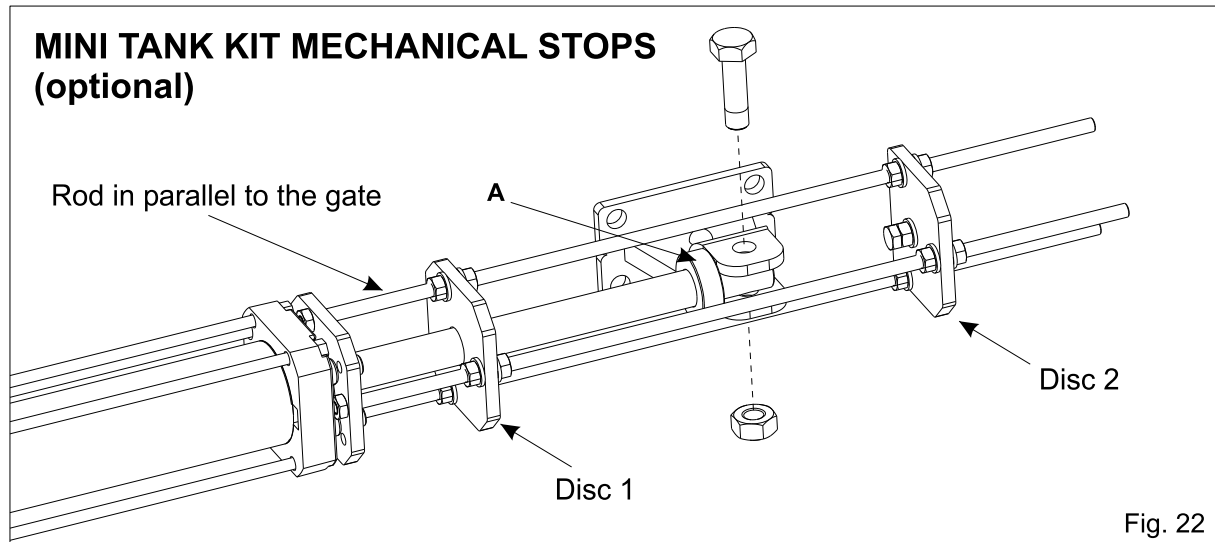

INSTALLATION OF THE CHROMIUM-PLATED ROD PROTECTION

Make sure to have inserted the antivibration plastic frame (A) before inserting the rod cover extrusion (Fig. 26).

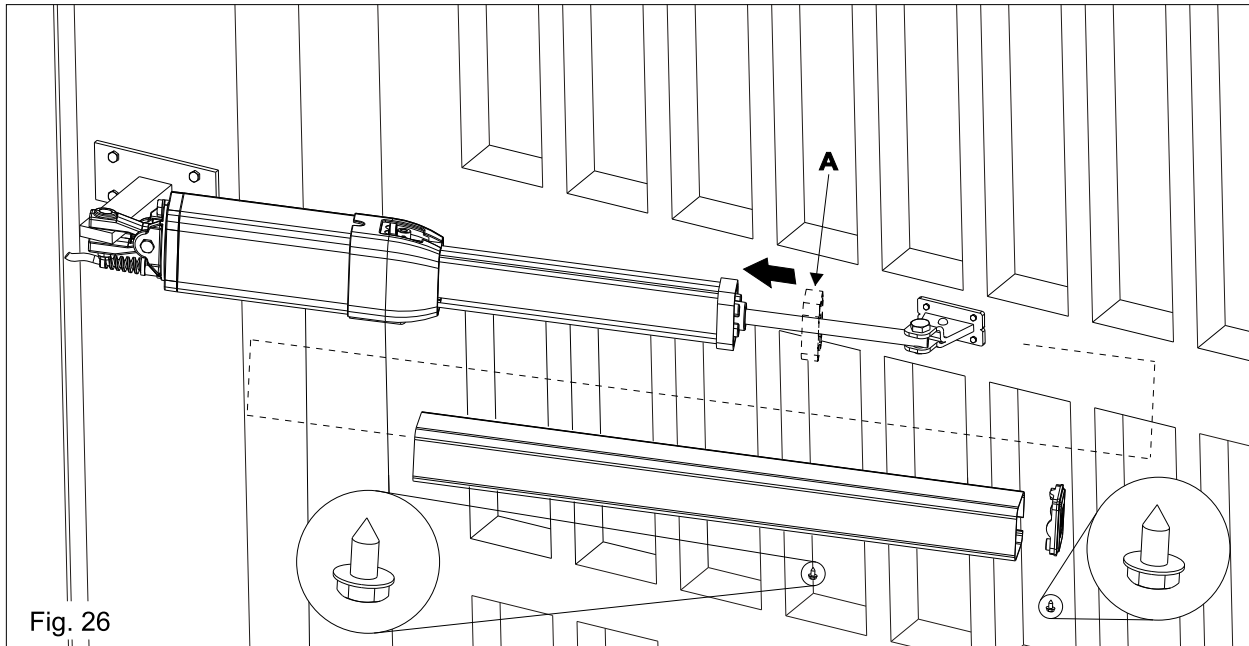

Fig. 26

TORQUE ADJUSTMENT (By-Pass Valves)

In case of first installation both, the cover of the release and the cover of the by pass valves must not yet be inserted. In this case refer to fig. 27 and fig.29.

Should the by-pass valves adjustment be made in a second moment, because of periodical maintenance or other, take off the screw which locks the by-pass cover (fig. 28), take off the by-pass cover and adjust the pressure of the by-pass valves with the special key given to the installer free of charge (Fig. 29).

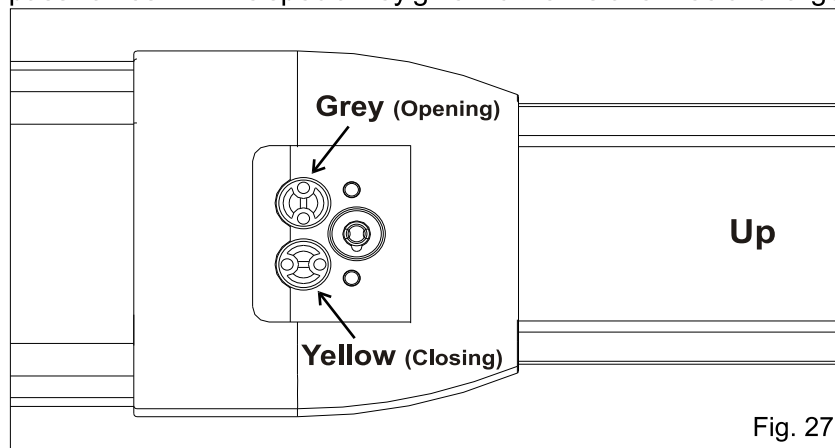

Fig. 27

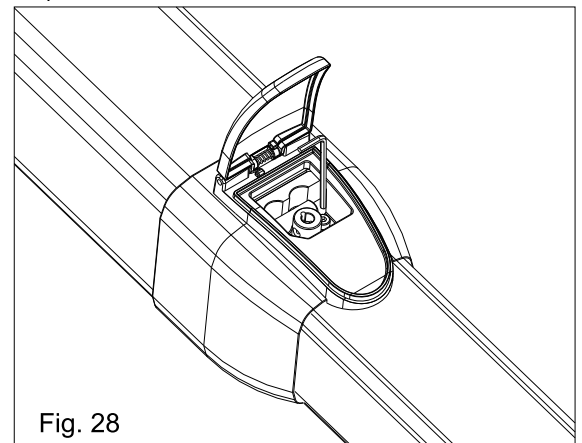
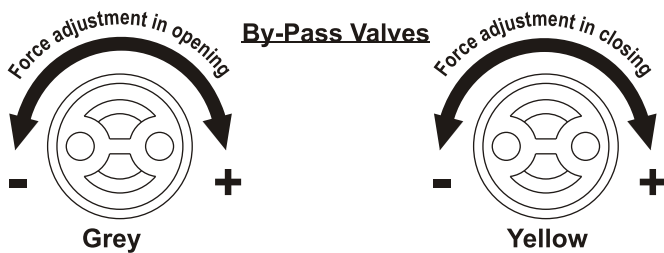

Fig. 28



Regulate the opening and closing forces of the gate respecting the force diagram (included in the En12453 normative); the thrust force however must not be superior then 15kgF.

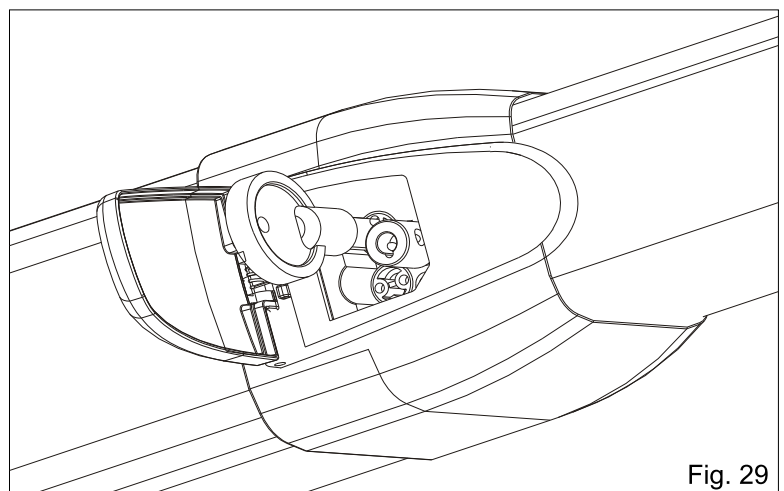
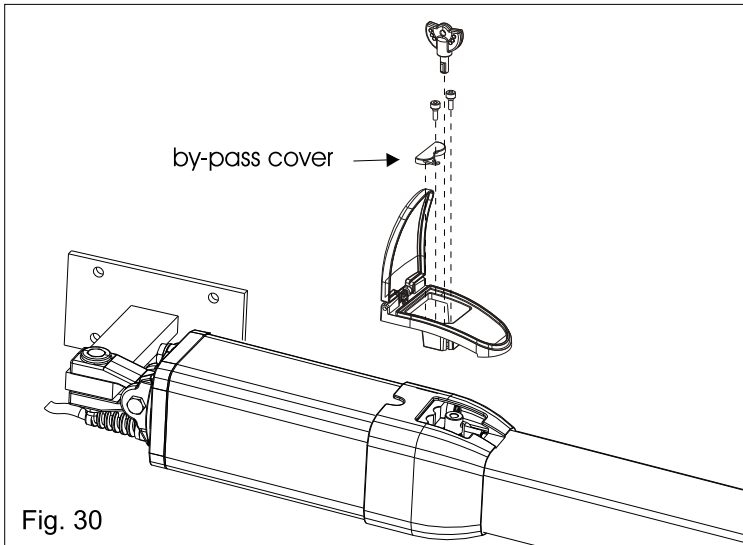

Fig. 29



PLASTIC RELEASE MOUNTING

ATTENTION: the mounting of the plastic release must be effectuated as shown in fig. 30 **only and exclusively** after having finished all the instalation operations, mounting of the rod cover and calibration of the by-pass valves.

ALUMINIUM RELEASE WITH KEY MOUNTING (accessory on request)

ATTENTION: The mounting of the aluminium release must be executed as shown in figure 31 only and exclusively after having finished all installation operations, the rod cover mounting and the calibration of the by pass valves.
The release key is kept in the inside of the aluminium release cover (see fig. 32).

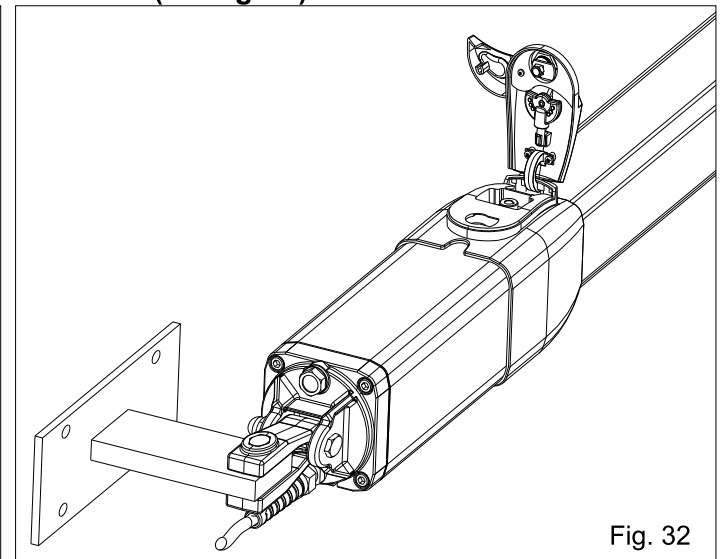
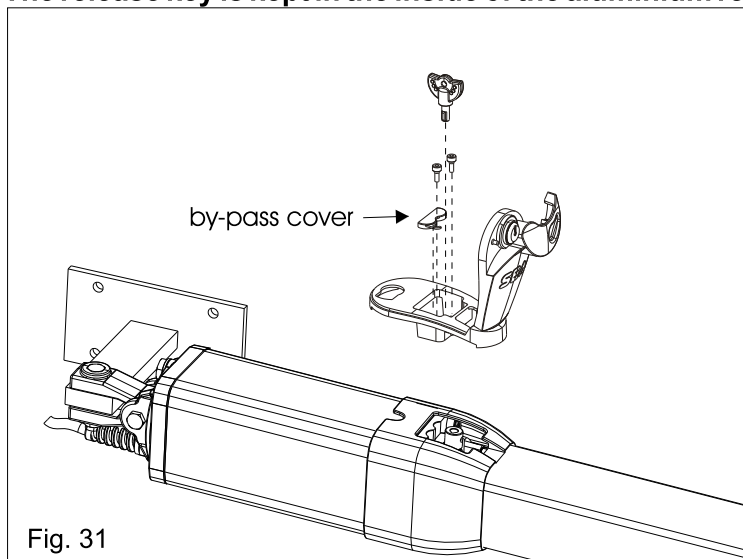

EXTERNAL RELEASE MOUNTING (accessory on request)

ATTENTION: The mounting of the external release must be executed as shown in the figures 33 and 34. For more details refer to the mounting instructions in the external release mounting Kit.

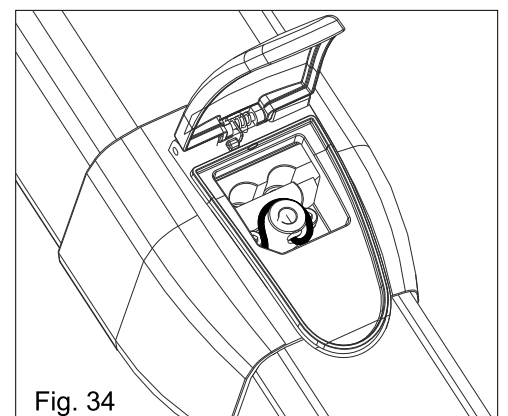
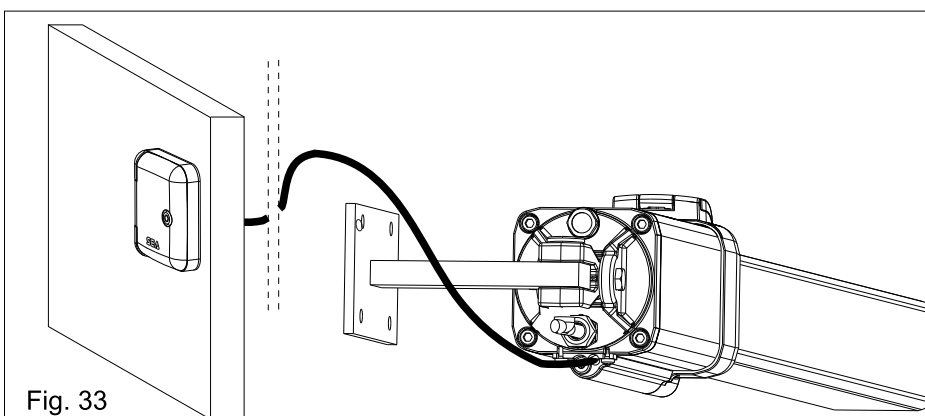

OIL LEVEL MEASUREMENT

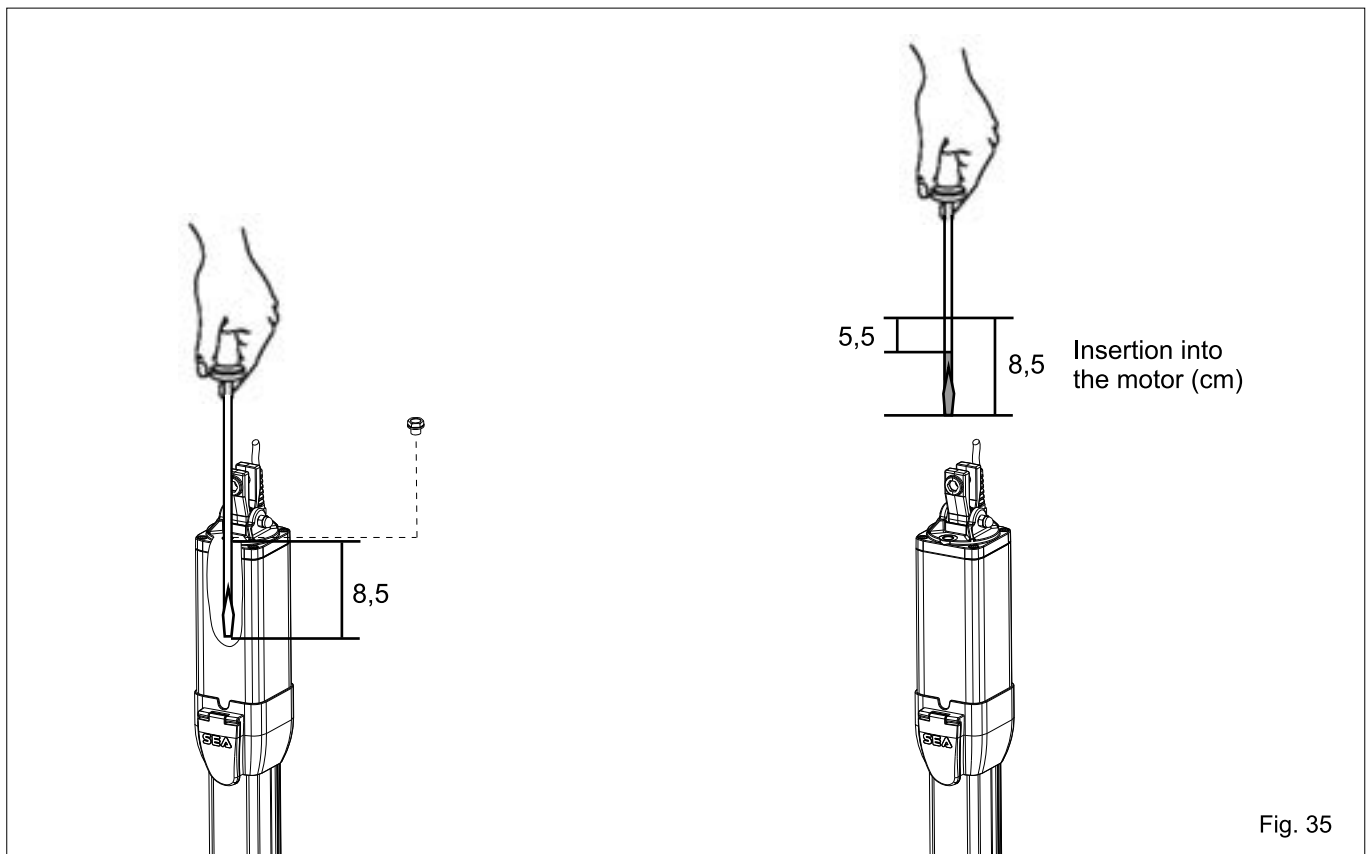

ACCESSORIES

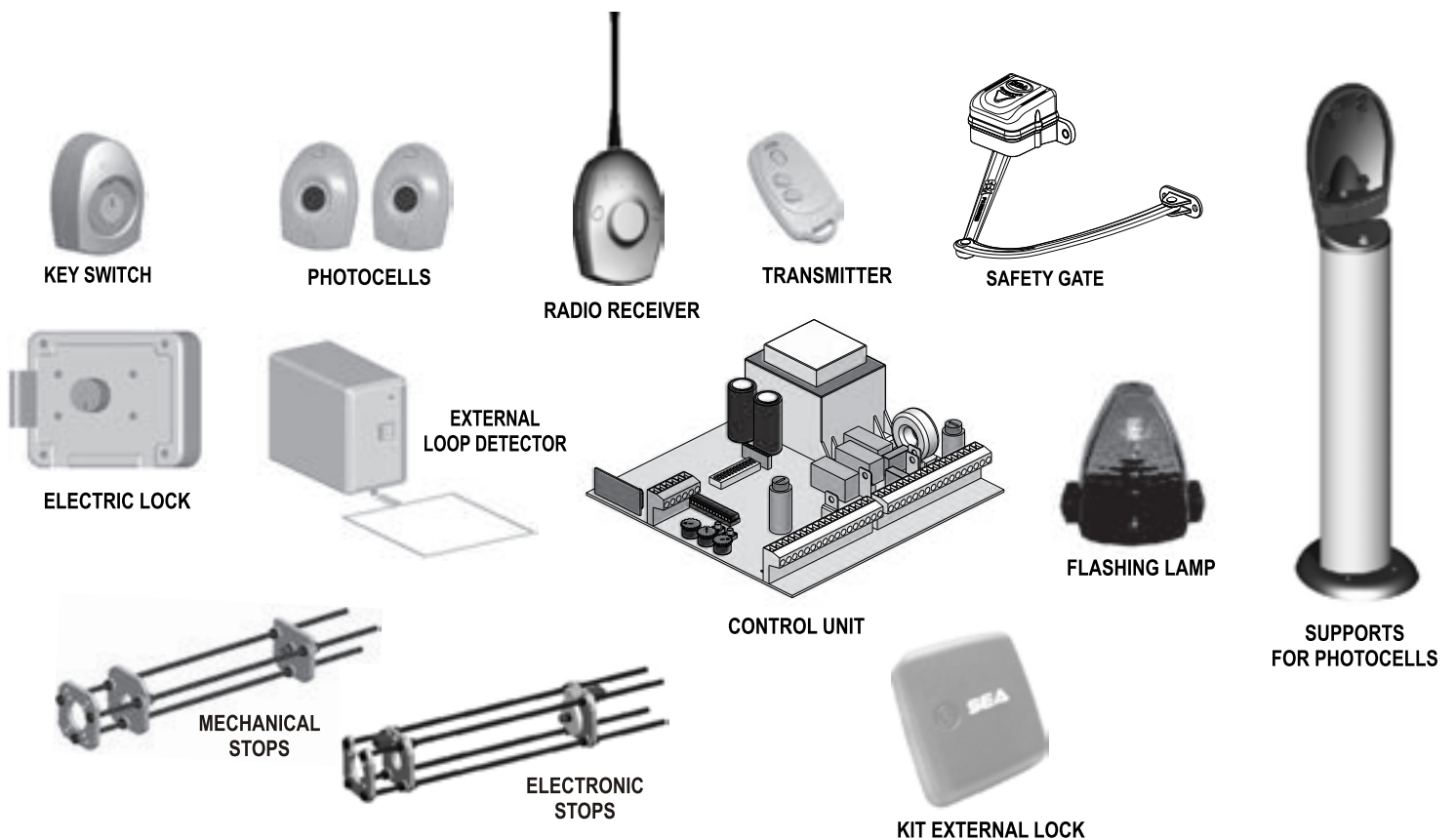

To the attention of users and technicians

RELEASE SYSTEM

To release operate as follows:

-Insert the key and turn it about 180° anti-clockwise (Fig.36 - Fig.37).

To relock the operator do as follows:

-Insert the key and turn it clockwise until it stops (Fig.36 - Fig.37).

Attention: To release cut current supply

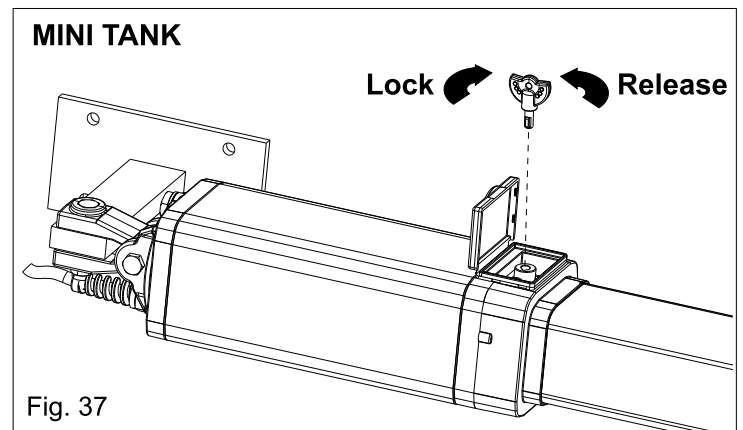
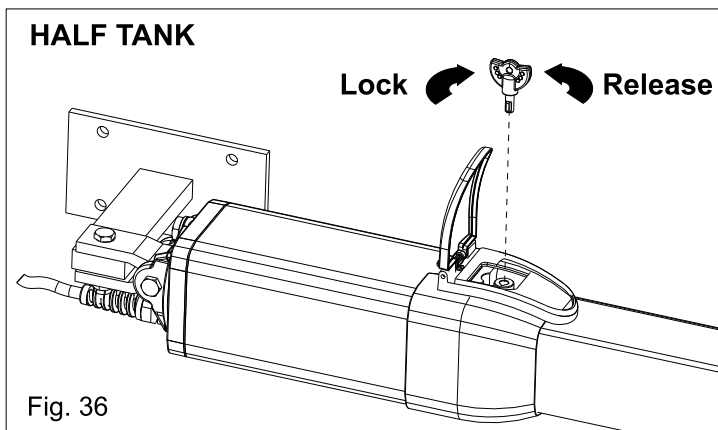

PERIODICAL MAINTENANCE

1) Check the robustness and the stability of the gate; particularly the leaning and/or rotation points of the gate (hinges).	Annual
2) Check the oil level in the hydraulic/in oil bath operators (cap on the back cover of the operator)	Annual
3) Replace the hydraulic oil with the oil recommended by the producer	4 Years
4) Check the function of the release	Annual
5) Check the function of the by-pass valves	Annual
6) Check and grease the fixation pivots	Annual
7) Check the integrity of the connecting cables	Annual
8) Check the function and the conditions of the limit switch stops in opening and closing (where the mechanical stop accessory is present)	Annual
9) Check the good status of all the apparatus which are subject to efforts (back fixation, oscillating fork, and front fixation)	Annual
10) Check the functionality of all the accessories especially the function of all security devices and of the Safety Gate.	Annual
11) Lubricate the rod (see page 19) with SEA grease (GREASE GL 00 Cod.65000009)	Annual
12) After having executed the periodical maintenance it is necessary to repeat the test and to reactivate the automation.	Annual

All the above mentioned operations must be executed by an authorised installer only.

To the attention of users and technicians

RISK EXAMINATION

The points indicated by arrows in Fig. 38 are potentially dangerous. The installer must take a thorough risk examination to prevent crushing, conveying, cutting, grasping, trapping so as to guarantee a safe installation for people, animals and things. As for misunderstandings that may arise refer to area distributor or call our help desk. These instructions are part of the device and must be kept in a well known place. The installer shall follow the provided instructions thoroughly. SEA S.p.A. products must only be used for the automation of doors, gates and wings. Any initiative taken without SEA S.p.A. explicit authorization will preserve the manufacture from whatsoever responsibility. The installer shall provide warning notices on not assessable further risks. SEA S.p.A. in its relentless aim to improve the production, is allowed to make whatsoever adjustment without giving notice. This does not oblige SEA S.p.A. to up-grade the past productions. SEA S.p.A. can not be deemed responsible for any damage or accident caused by product breaking, being damages or accident due to a failure to comply with the instructions herein. The guarantee will be void and the manufacturer responsibility will be nullified if SEA S.p.A. original spare parts are not being used. The electric installation shall be carried out by a professional technician who will release documentation as requested by the laws in force. Packaging materials such as plastic bags, foam polystyrene, nails etc. must be kept out of children s reach as dangers may arise.

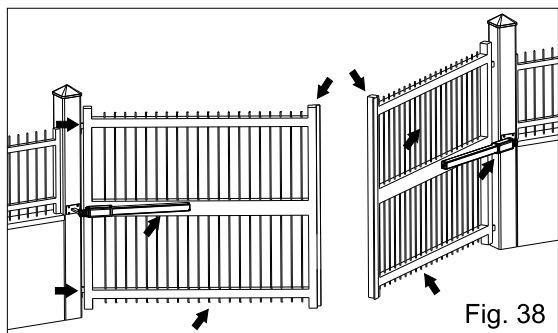

Fig. 38

INITIAL CHECK AND PUTTING IN SERVICE

After having completed all necessary operations, for the correct installation of the products, described in the present manual and after having valued all resting risks which could arise in whatever installation **is necessary to test the automations to guarantee the max. security** and in particular way to guarantee the respect of what foreseen by the law and the normatives in force. In particular the test must be executed following

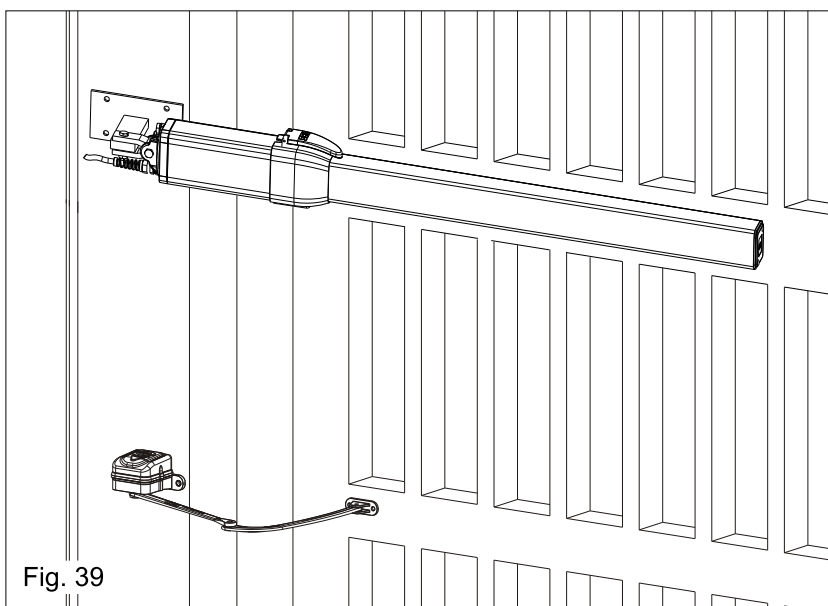

Fig. 39

the **EN12445** ruel which establishes the testing methods for the testing of the gate operators respecting the established limits by the **EN 12453** law.

SAFETY GATE

For a correct and safe installation it is strongly recommended to install the Safety Gate, **which allows the fulfilment of the force diagram included in the EN 12453** ruel and the testing of the putting in service and of the whole installation.

NOTE: In case of installations as shown in the figure on the right it is possible to use the Safety Gate with a straight rod, solving the dimensions problem of the arm.

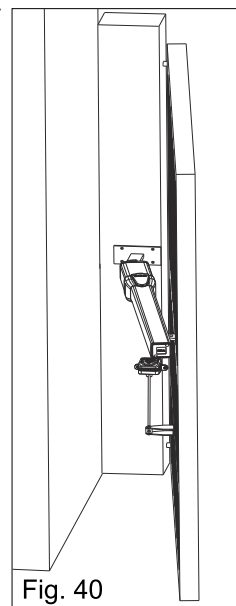

Fig. 40

SAFETY PRECAUTIONS

All electrical installation work should conform to current regulations.

A 16A - 0,030A differential switch must be incorporated into the source of the gate main electrical supply and the entire system must be properly earth bonded. Remember to separate mains (230/120V) carrying cables from low voltage control cables.

INTENDED USE

The Half Tank and Mini Tank in all their versions have been planned to be used exclusively for the automation of swing gates

SPARE PARTS

To obtain spare parts contact: **SEA S.p.A. ZONA Ind.le, 64020 S.ATTO Teramo Italia**

SAFETY AND ENVIRONMENTAL COMPATIBILITY

Please dispose of the product and circuit packing materials in a responsible and appropriate way.

When being transported this product must be properly packaged and handled with care.

MAINTENANCE AND DECOMMISSION

The decommission and maintenance of these unities must be carried out by specialised and authorised personnel only.

LIMIT OF GUARANTEE

For the guarantee see the sales conditions on the official SEA price list.

NOTE: THE MANUFACTURER CAN NOT BE DEEMED RESPONSIBLE FOR ANY DAMAGE OR INJURY CAUSED BY IMPROPER USE OF THIS PRODUCT.

SEA reserves the right to do changes or variations that may be necessary to its products with no obligation to notice.

CONDIZIONI DI VENDITA

EFFICACIA DELLE PRESENTI CONDIZIONI GENERALI DI VENDITA: Le presenti condizioni generali di vendita si applicano a tutti gli ordini indirizzati a SEA S.p.A. Tutte le vendite fatte da SEA ai clienti sono regolate secondo le presenti condizioni di vendita che costituiscono parte integrante del contratto di vendita ed annullano ogni clausola contraria o pattuizioni particolari presenti nell'ordine o in altro documento proveniente dall'acquirente (cliente)

AVVERTENZE GENERALI Gli impianti di automazione porte e cancelli vanno realizzati esclusivamente con componenti SEA, salvo accordi specifici. L'inosservanza delle norme di sicurezza vigenti (Norm. EUROPEE EN 12453 - EN 12445 e altro) e di buona tecnica esclude la SEA da ogni responsabilità. La SEA non risponde del mancato rispetto della corretta e sicura installazione secondo le norme.

1) PROPOSTA D'ORDINE La proposta d'ordine si intenderà accettata solo dopo la sua approvazione da parte della SEA. Conseguenza della sua sottoscrizione, l'acquirente sarà vincolato alla stipula di un contratto d'acquisto, secondo quanto contenuto nella stessa proposta d'ordine e nelle presenti condizioni di vendita. Viceversa, la mancata comunicazione all'acquirente dell'approvazione della proposta d'ordine, non comporta la sua automatica accettazione da parte della SEA

2) VALIDITÀ OFFERTA Le offerte proposte dalla SEA o dalla sua struttura commerciale periferica, avranno una validità di 30 giorni solari, salvo diversa comunicazione in merito.

3) PREZZI I prezzi della proposta d'ordine sono quelli del listino in vigore alla data della redazione della stessa. Gli sconti applicati dalla struttura commerciale periferica della SEA si intenderanno validi solo dopo la loro accettazione da parte della SEA. I prezzi si intendono per merce resa franco ns. stabilimento in Teramo, esclusi IVA ed imballaggi speciali. La SEA si riserva il diritto di modificare in qualsiasi momento il listino, dando opportuno preavviso alla rete di vendita. Le condizioni speciali riservate agli acquisti con formula agevolata Qx, Qx1, Qx2, Qx3 sono riservate ai distributori ufficiali dietro accettazione scritta da parte della direzione SEA.

4) PAGAMENTI Le forme di pagamento ammesse sono quelle comunicate o accettate di volta in volta dalla SEA. Il tasso di interesse sul ritardo da pagamento è del 1,5% mensile e comunque non oltre il tasso massimo legalmente consentito.

5) CONSEGNA La consegna avverrà indicativamente ma non tassativamente entro 30 giorni lavorativi dalla data di ricezione dell'ordine, salvo diverse comunicazioni in merito. Il trasporto degli articoli venduti sarà effettuato a spese ed a rischio dell'acquirente. La SEA si libera dall'obbligo della consegna rimettendo la merce al vettore, sia esso scelto dalla SEA oppure dall'acquirente. Eventuali smarrimenti e/o danneggiamenti della merce dovuti al trasporto, sono a carico dell'acquirente.

6) RECLAMI Eventuali reclami e/o contestazioni dovranno pervenire alla SEA entro 8 giorni solari dalla ricezione della merce, supportati da idonei documenti provanti la loro veridicità.

7) FORNITURA L'ordine in oggetto viene assunto da SEA senza alcun impegno e subordinatamente alle possibilità di approvvigionamento delle materie prime occorrenti alla produzione; eventuali mancate esecuzioni totali o parziali non possono dar luogo a reclami e riserve per danni. La fornitura SEA è strettamente limitata alla sola merce di sua produzione, esclusi il montaggio, l'installazione ed il collaudo. La SEA declina pertanto ogni responsabilità per danni che dovessero derivare, anche a terzi, dall'inosservanza delle norme di sicurezza e della buona regola d'arte nelle fasi dell'installazione e dell'impiego dei prodotti venduti.

8) GARANZIA La garanzia minima è di 12 mesi e può essere estesa, come di seguito, in caso di riconsegna del certificato di garanzia.

SILVER: Le parti meccaniche degli operatori rientranti in tale categoria sono garantite per 24 mesi dalla data di fabbricazione riportata sull'operatore.

GOLD: Le parti meccaniche degli operatori rientranti in tale categoria sono garantite per 36 mesi dalla data di fabbricazione riportata sull'operatore.

PLATINUM: Le parti meccaniche degli operatori rientranti in tale categoria sono garantite per 36 mesi dalla data di fabbricazione riportata sull'operatore. La garanzia di base (36 mesi) sarà estesa per ulteriori 24 mesi (fino ad un totale di 60 mesi) qualora venga acquistato il certificato di garanzia che dovrà essere compilato e rispedito alla SEA S.p.A. entro 60 giorni dall'acquisto. L'elettronica e le centrali di comando sono garantite per 24 mesi dalla data di fabbricazione. Nelleventualità di difettosità del prodotto, la SEA si impegna alla sua sostituzione gratuita oppure alla sua riparazione, previa restituzione al proprio centro di riparazione. La definizione di stato di garanzia è ad insindacabile giudizio della SEA. I pezzi sostitutivi restano di proprietà della SEA. In modo vincolante, il materiale dell'acquirente ritenuto in garanzia deve essere spedito al centro di riparazione della SEA in porto franco e sarà rispedito dalla SEA in porto assegnato. La garanzia non si estende alla manodopera eventualmente accorsa. I difetti riconosciuti non produrranno alcuna responsabilità e/o richiesta di danni, di qualsiasi natura essi siano, da parte dell'acquirente nei riguardi della SEA. La garanzia non è in ogni caso riconosciuta qualora sia stata apportata alla merce qualsivoglia modifica, oppure vi sia stato un uso improprio, oppure si sia in presenza di una qualsivoglia sua manomissione o di un montaggio non corretto, oppure se sia stata rimossa l'etichetta a apposta dal produttore comprensiva del marchio SEA registrato n° 804888. La garanzia non è inoltre valida nel caso la merce SEA sia stata in parte o in toto accoppiata a componenti meccanici e/o elettronici non originali, ed in particolare in assenza di una specifica autorizzazione in merito, ed inoltre nel caso in cui l'acquirente non sia in regola con i pagamenti. La garanzia non comprende danni derivati dal trasporto, materiale di consumo, avarie dovute al mancato rispetto delle specifiche prestazionali dei prodotti indicate nel listino. Non è riconosciuto alcun indennizzo durante il tempo di riparazione e/o sostituzione della merce in garanzia. La SEA declina ogni responsabilità per danni a cose o persone derivanti dall'inosservanza delle norme di sicurezza e della non conforme installazione o dall'impiego errato dei prodotti venduti. La riparazione dei prodotti in garanzia e fuori garanzia è subordinata al rispetto delle procedure comunicate da SEA.

9) RISERVATO DOMINIO Sulla merce venduta è valida la clausola del riservato dominio, della quale la SEA deciderà autonomamente se avvalersi o meno, in virtù della quale l'acquirente acquisisce la proprietà della merce, solo dopo che il suo pagamento sia stato completamente effettuato.

10) FORO COMPETENTE Per qualsiasi controversia avente per oggetto l'applicazione di questo contratto, viene eletto competente il Foro di Teramo. La lingua valida nell'interpretazione di cataloghi, manuali di installazione, condizioni di vendita o altro è quella italiana. La SEA si riserva la facoltà di apportare modifiche tecniche atte a migliorare i propri prodotti, presenti o meno in questo Listino, in qualsiasi momento senza preavviso. La SEA declina ogni responsabilità derivante da possibili inesattezze contenute nel presente listino, derivanti da errori di stampa e/o trascrizione. Il presente Listino annulla e sostituisce quelli precedenti. L'acquirente ai sensi della legge 196/2003 (codice privacy) acconsente all'inserimento dei propri dati personali derivanti dal presente contratto negli archivi informativi e cartacei della SEA S.p.A. al loro trattamento per motivi commerciali ed amministrativi.

Diritti di proprietà industriale: il cliente, con l'acquisto, accetta le presenti condizioni di vendita e riconosce in capo a SEA la titolarità esclusiva del marchio internazionale SEA registrato n. 804888 apposto sulle etichette dei prodotti e/o sui manuali e/o su ogni altra documentazione, e si impegna ad utilizzare il medesimo nella propria attività di rivendita e/o installazione secondo modalità che non ne riducano in alcun modo i diritti, a non rimuovere, sostituire o alterare marchi o altri segni distintivi di qualsiasi genere apposti ai prodotti.

È vietata ogni forma di riproduzione o utilizzo del marchio SEA e di ogni altro segno distintivo presente sui prodotti, salvo autorizzazione scritta di SEA S.p.A..

Agli effetti dell'articolo 1341 del C.C. si approvano specificamente per iscritto le clausole di cui ai numeri:

4) PAGAMENTI - 8) GARANZIA - 10) FORO COMPETENTE

TERMS OF SALES

EFFICACY OF THE FOLLOWING TERMS OF SALE: the following general terms of sale shall be applied to all orders sent to SEAS.p.A. All sales made by SEA to all costumers are made under the prescription of this terms of sales which are integral part of sale contract and cancel and substitute all apposed clauses or specific negotiations present in order document received from the buyer.

GENERAL NOTICE The systems must be assembled exclusively with SEA components, unless specific agreements apply. Non-compliance with the applicable safety standards (European Standards EM12453 EM 12445) and with good inst allation practice releases SEA from any responsibilities. SEA shall not be held responsible for any failure to execute a correct and safe installation under the above mentioned standards.

1) PROPOSED ORDER The proposed order shall be accepted only prior SEA approval of it. By signing the proposed order, the Buyer shall be bound to enter a purchase agreement, according to the specifications stated in the proposed order.

On the other hand, failure to notify the Buyer of said approval must not be construed as automatic acceptance on the part of SEA.

2) PERIOD OF THE OFFER The offer proposed by SEA or by its branch sales department shall be valid for 30 solar days, unless otherwise notified.

3) PRICING The prices in the proposed order are quoted from the Price List which is valid on the date the order was issued. The discounts granted by the branch sales department of SEA shall apply only prior to acceptance on the part of SEA. The prices are for merchandise delivered ex-works from the SEA establishment in Teramo, not including VAT and special packaging. SEA reserves the right to change at any time this price list, providing timely notice to the sales network. The special sales conditions with extra discount on quantity basis (Qx, Qx1, Qx2, Qx3 formula) is reserved to official distributors under SEA management written agreement.

4) PAYMENTS The accepted forms of payment are each time notified or approved by SEA. The interest rate on delay in payment shall be 1.5% every month but anyway shall not be higher than the max. interest rate legally permitted.

5) DELIVERY Delivery shall take place, approximately and not peremptorily, within 30 working days from the date of receipt of the order, unless otherwise notified. Transport of the goods sold shall be at Buyer s cost and risk. SEA shall not bear the costs of delivery giving the goods to the carrier, as chosen either by SEA or by the Buyer. Any loss and/or damage of the goods during transport, are at Buyer s cost.

6) COMPLAINTS Any complaints and/or claims shall be sent to SEA within 8 solar days from receipt of the goods, proved by adequate supporting documents as to their truthfulness.

7) SUPPLY The concerning order will be accepted by SEA without any engagement and subordinately to the possibility to get it s supplies of raw material which is necessary for the production; Eventual completely or partially unsuccessful executions cannot be reason for complains or reservations for damage. SEA supply is strictly limited to the goods of its manufacturing, not including assembly, installation and testing. SEA, therefore, disclaims any responsibility for damage deriving, also to third parties, from non-compliance of safety standards and good practice during installation and use of the purchased products.

8) WARRANTY The standard warranty period is 12 months. This warranty time can be extended by means of expedition of the warranty coupon as follows:

SILVER: The mechanical components of the operators belonging to this line are guaranteed for 24 months from the date of manufacturing written on the operator.

GOLD: The mechanical components of the operators belonging to this line are guaranteed for 36 months from the date of manufacturing written on the operator.

PLATINUM: The mechanical components of the operators belonging to this line are guaranteed for 36 months from the date of manufacturing written on the operator. The base warranty (36 months) will be extended for further 24 months (up to a total of 60 months) when it is acquired the certificate of warranty which will be filled in and sent to SEA S.p.A. The electronic devices and the systems of command are guaranteed for 24 months from the date of manufacturing. In case of defective product, SEA undertakes to replace free of charge or to repair the goods provided that they are returned to SEA repair centre. The definition of warranty status is by unquestionable assessment of SEA. The replaced parts shall remain propriety of SEA. Binding upon the parties, the material held in warranty by the Buyer, must be sent back to SEA repair centre with fees prepaid, and shall be dispatched by SEA with carriage forward. The warranty shall not cover any required labour activities.

The recognized defects, whatever their nature, shall not produce any responsibility and/or damage claim on the part of the Buyer against SEA. The guarantee is in no case recognized if changes are made to the goods, or in the case of improper use, or in the case of tampering or improper assembly, or if the label affixed by the manufacturer has been removed including the SEA registered trademark No. 804888. Furthermore, the warranty shall not apply if SEA products are partly or completely coupled with non-original mechanical and/or electronic components, and in particular, without a specific relevant authorization, and if the Buyer is not making regular payments. The warranty shall not cover damage caused by transport, expendable material, faults due to non-conformity with performance specifications of the products shown in the price list. No indemnification is granted during repairing and/or replacing of the goods in warranty. SEA disclaims any responsibility for damage to objects and persons deriving from non-compliance with safety standards, installation instructions or use of sold goods. The repair of products under warranty and out of warranty is subject to compliance with the procedures notified by SEA.

9) RESERVED DOMAIN A clause of reserved domain applies to the sold goods; SEA shall decide autonomously whether to make use of it or not, whereby the Buyer purchases propriety of the goods only after full payment of the latter.

10) COMPETENT COURT OF LAW In case of disputes arising from the application of the agreement, the competent court of law is the tribunal of Teramo. SEA reserves the faculty to make technical changes to improve its own products, which are not in this price list at any moment and without notice. SEA declines any responsibility due to possible mistakes contained inside the present price list caused by printing and/or copying. The present price list cancels and substitutes the previous ones. The Buyer, according to the law No. 196/2003 (privacy code) consents to put his personal data, deriving from the present contract, in SEA archives and electronic files, and he also gives his consent to their treatment for commercial and administrative purposes.

Industrial ownership rights: once the Buyer has recognized that SEA has the exclusive legal ownership of the registered SEA brand num.804888 affixed on product labels and / or on manuals and / or on any other documentation, he will commit himself to use it in a way which does not reduce the value of these rights, he wont also remove, replace or modify brands or any other p articularity from the products. Any kind of replication or use of SEA brand is forbidden as well as of any particularity on the products, unless preventive and expressed authorization by SEA.

In accomplishment with art. 1341 of the Italian Civil Law it will be approved expressly clauses under numbers:

4) PAYMENTS - 8) GUARANTEE - 10) COMPETENT COURT OF LOW

Italiano AVVERTENZE GENERALI PER INSTALLATORE E UTENTE

1. Leggere attentamente le **Istruzioni di Montaggio** e le **Avvertenze Generali** prima di iniziare l'installazione del prodotto. Conservare la documentazione per consultazioni future
2. Non disperdere nell'ambiente i materiali di imballaggio del prodotto e/o circuiti
3. Questo prodotto è stato progettato e costruito esclusivamente per l'utilizzo indicato in questa documentazione. Qualsiasi altro utilizzo non espressamente indicato potrebbe pregiudicare l'integrità del prodotto e/o rappresentare fonte di pericolo. L'uso improprio è anche causa di cessazione della garanzia. La SEA S.p.A. declina qualsiasi responsabilità derivata dall'uso improprio o diverso da quello per cui l'automatismo è destinato.
4. I prodotti SEA sono conformi alle Direttive: Macchine (2006/42/CE e successive modifiche), Bassa Tensione (2006/95/CE e successive modifiche), Compatibilità Elettromagnetica (2004/108/CE e successive modifiche). L'installazione deve essere effettuata nell'osservanza delle norme EN 12453 e EN 12445.
5. Non installare l'apparecchio in atmosfera esplosiva.
6. SEA S.p.A. non è responsabile dell'osservanza della Buona Tecnica nella costruzione delle chiusure da motorizzare, nonché delle deformazioni che dovessero verificarsi durante l'uso.
7. Prima di effettuare qualsiasi intervento sull'impianto, togliere l'alimentazione elettrica e scollegare le batterie. Verificare che l'impianto di terra sia realizzato a regola d'arte e collegarvi le parti metalliche della chiusura.
8. Per ogni impianto SEA S.p.A. consiglia l'utilizzo di almeno una segnalazione luminosa nonché di un cartello di segnalazione fissato adeguatamente sulla struttura dell'infisso.
9. SEA S.p.A. declina ogni responsabilità ai fini della sicurezza e del buon funzionamento della automazione, in caso vengano utilizzati componenti di altri produttori.
10. Per la manutenzione utilizzare esclusivamente parti originali SEA.
11. Non eseguire alcuna modifica sui componenti dell'automazione.
12. L'installatore deve fornire tutte le informazioni relative al funzionamento manuale del sistema in caso di emergenza e consegnare all'utente utilizzatore dell'impianto il libretto di avvertenze allegato al prodotto.
13. Non permettere ai bambini o persone di sostare nelle vicinanze del prodotto durante il funzionamento. L'applicazione non può essere utilizzata da bambini, da persone con ridotte capacità fisiche, mentali, sensoriali o da persone prive di esperienza o del necessario addestramento. Tenere inoltre fuori dalla portata dei bambini i telecomandi o qualsiasi altro datore di impulso, per evitare che l'automazione possa essere azionata involontariamente.
14. Il transito tra le ante deve avvenire solo a cancello completamente aperto.
15. Tutti gli interventi di manutenzione, riparazione o verifiche periodiche devono essere eseguiti da personale professionalmente qualificato. L'utente deve astenersi da qualsiasi tentativo di riparazione o intervento e deve rivolgersi esclusivamente a personale qualificato SEA. L'utente può eseguire solo la manovra manuale.
16. La lunghezza massima dei cavi di alimentazione fra centrale e motori non deve essere superiore a 10 m. Utilizzare cavi con sezione 2,5 mm². Utilizzare cablaggi con cavi in doppio isolamento (cavi con guaina) nelle immediate vicinanze dei morsetti specie per il cavo di alimentazione (230V). Inoltre è necessario mantenere adeguatamente lontani (almeno 2,5 mm in aria) i conduttori in bassa tensione (230V) dai conduttori in bassissima tensione di sicurezza (SELV) oppure utilizzare un'adeguata guaina che fornisca un isolamento supplementare avente uno spessore di almeno 1 mm.

English GENERAL NOTICE FOR THE INSTALLER AND THE USER

1. Read carefully these **Instructions** before beginning to install the product. Store these instructions for future reference
2. Don't waste product packaging materials and/or circuits.
3. This product was designed and built strictly for the use indicated in this documentation. Any other use, not expressly indicated here, could compromise the good condition/operation of the product and/or be a source of danger. SEA S.p.A. declines all liability caused by improper use or different use in respect to the intended one.
4. The mechanical parts must comply with Directives: Machine Regulation 2006/42/CE and following adjustments), Low Tension (2006/95/CE), electromagnetic Consistency (2004/108/CE) Installation must be done respecting Directives: EN12453 and EN12445.
5. Do not install the equipment in an explosive atmosphere.
6. SEA S.p.A. is not responsible for failure to observe Good Techniques in the construction of the locking elements to motorize, or for any deformation that may occur during use.
7. Before attempting any job on the system, cut out electrical power and disconnect the batteries. Be sure that the earthing system is perfectly constructed, and connect it metal parts of the lock.
8. Use of the indicator-light is recommended for every system, as well as a warning sign well-fixed to the frame structure.
9. SEA S.p.A. declines all liability as concerns the automated systems security and efficiency, if components used, are not produced by SEA S.p.A..
10. For maintenance, strictly use original parts by SEA.
11. Do not modify in any way the components of the automated system.
12. The installer shall supply all information concerning system's manual functioning in case of emergency, and shall hand over to the user the warnings handbook supplied with the product.
13. Do not allow children or adults to stay near the product while it is operating. The application cannot be used by children, by people with reduced physical, mental or sensorial capacity, or by people without experience or necessary training. Keep remote controls or other pulse generators away from children, to prevent involuntary activation of the system.
14. Transit through the leaves is allowed only when the gate is fully open.
15. The User must not attempt to repair or to take direct action on the system and must solely contact qualified SEA personnel or SEA service centers. User can apply only the manual function of emergency.
16. The power cables maximum length between the central engine and motors should not be greater than 10 m. Use cables with 2,5 mm² section. Use double insulation cable (cable sheath) to the immediate vicinity of the terminals, in particular for the 230V cable. Keep an adequate distance (at least 2.5 mm in air), between the conductors in low voltage (230V) and the conductors in low voltage safety (SELV) or use an appropriate sheath that provides extra insulation having a thickness of 1 mm.

Français CONSIGNES POUR L'INSTALLATEUR ET L'UTILISATEUR

1. Lire attentivement les **instructions** avant d'installer le produit. Conserver les instructions en cas de besoin.
2. Ne pas disperser dans l'environnement le matériel d'emballage du produit et/ou des circuits
4. Ce produit a été conçu et construit exclusivement pour l'usage indiqué dans cette fiche. Toute autre utilisation non expressément indiquée pourrait compromettre l'intégrité du produit et/ou représenter une source de danger. SEA S.p.A. décline toute responsabilité qui dériverait d'un usage impropre ou différent de celui auquel l'automatisme est destiné. Une mauvaise utilisation cause la cessation de la garantie.
5. Les composants doivent répondre aux prescriptions des Normes: Machines (2006/42/CE et successifs changements); Basse Tension (2006/95/CE et successifs changements); EMC (2004/108/CE et successifs changements). L'installation doit être effectuée conformément aux Normes EN 12453 et EN 12445.
6. Ne pas installer l'appareil dans une atmosphère explosive.
7. SEA S.p.A. n'est pas responsable du non-respect de la Bonne Technique de construction des fermetures à motoriser, ni des déformations qui pourraient intervenir lors de l'utilisation.
8. Couper l'alimentation électrique et déconnecter la batterie avant toute intervention sur l'installation. Vérifier que la mise à terre est réalisée selon les règles de l'art et y connecter les pièces métalliques de la fermeture.
9. On recommande que toute installation soit dotée au moins d'une signalisation lumineuse, d'un anneau de signalisation fixé, de manière appropriée, sur la structure de la fermeture.
10. SEA S.p.A. décline toute responsabilité quant à la sécurité et au bon fonctionnement de l'automatisme si les composants utilisés dans l'installation n'appartiennent pas à la production SEA.



11. Utiliser exclusivement, pour l'entretien, des pièces SEA originales.
12. Ne jamais modifier les composants d'automatisme.
13. L'installateur doit fournir toutes les informations relatives au fonctionnement manuel du système en cas d'urgence et remettre à l'utilisateur qui utilise l'installation les Instructions pour l'utilisateur fournies avec le produit.
14. Interdire aux enfants ou aux tiers de stationner près du produit durant le fonctionnement. Ne pas permettre aux enfants, aux personnes ayant des capacités physiques, mentales et sensorielles limitées ou dépourvues de l'expérience ou de la formation nécessaires d'utiliser l'application en question. Eloigner de la portée des enfants les radiocommandes ou tout autre générateur d'impulsions, pour éviter tout actionnement involontaire de l'automatisme.
15. Le transit entre les vantaux ne doit avoir lieu que lorsque le portail est complètement ouvert.
16. L'utilisateur doit s'abstenir de toute tentative de réparation ou d'intervention et doit s'adresser uniquement et exclusivement au personnel qualifié SEA ou aux centres d'assistance SEA. L'utilisateur doit garder le document relatif à la réparation. L'utilisateur peut exécuter seulement la manœuvre manuelle.
17. La longueur maximum des câbles d'alimentation entre la carte et les moteurs ne devrait pas être supérieure à 10 m. Utilisez des câbles avec une section de 2,5 mm². Utilisez des câbles avec double isolation (avec gaine) jusqu'à proximité immédiate des terminaux, en particulier pour le câble d'alimentation (230V). Il est également nécessaire de maintenir une distance suffisante (au moins 2,5 mm dans l'air), entre les conducteurs en basse tension (230V) et les conducteurs de très basse tension de sécurité (SELV) ou utiliser une gaine ayant une épaisseur d'au moins 1 mm, qui fournisse une isolation supplémentaire.

Español ADVERTENCIAS GENERALES PARA INSTALADORES Y USUARIOS

1. Leer las **instrucciones de instalación** antes de comenzar la instalación. Mantenga las instrucciones para consultas futuras.
2. No desperdiciar en el ambiente los materiales de embalaje del producto o del circuito.
3. Este producto fue diseñado y construido exclusivamente para el uso especificado en esta documentación. Cualquier otro uso no expresamente indicado puede afectar la integridad del producto y ser una fuente de peligro. El uso inadecuado es también causa de anulación de la garantía. SEA S.p.A. se exime de toda responsabilidad causadas por uso inapropiado o diferente de aquel para el que el sistema automatizado fue producido.
4. Los productos cumplen con la Directiva: Maquinas (2006/42/CE y siguientes modificaciones), Baja Tensión (2006/95/CE, y siguientes modificaciones), Compatibilidad Electromagnética (2004/108/CE modificada). La instalación debe ser llevada a cabo de conformidad a las normas EN 12453 y EN 12445.
5. No instalar el dispositivo en una atmósfera explosiva.
6. SEA S.p.A. no es responsable del incumplimiento de la mano de obra en la construcción de la cancela a automatizar y tampoco de las deformaciones que puedan producirse durante el uso.
7. Antes de realizar cualquier operación apagar la fuente de alimentación y desconectar las baterías. Comprobar que el sistema de puesta a tierra sea diseñado de una manera profesional y conectar las partes metálicas del cierre.
8. Para cada instalación se recomienda utilizar como mínimo una luz parpadeante y una señal de alarma conectada a la estructura del marco.
9. SEA S.p.A. no acepta responsabilidad por la seguridad y el buen funcionamiento de la automatización en caso de utilización de componentes no producidos por SEA.
10. Para el mantenimiento utilizar únicamente piezas originales SEA S.p.A..
11. No modificar los componentes del sistema automatizado.
12. El instalador debe proporcionar toda la información relativa al funcionamiento manual del sistema en caso de emergencia y darle al usuario el folleto de adjunto al producto.
13. No permita que niños o adultos permanezcan cerca del producto durante la operación. La aplicación no puede ser utilizada por niños, personas con movilidad reducida de tipo físico, mental, sensorial o igual por personas sin experiencia o formación necesaria. Tener los radiomandos fuera del alcance de niños así como cualquier otro generador de impulsos radio para evitar que el automatismo pueda ser accionado accidentalmente.
14. El tránsito a través de las hojas sólo se permite cuando la puerta está completamente abierta.
15. Todo el mantenimiento, reparación o controles deberán ser realizados por personal cualificado. Evitar cualquier intento de reparar o ajustar. En caso de necesidad comunicarse con un personal SEA calificado. Sólo se puede realizar la operación manual.
16. La longitud máxima de los cables de alimentación entre motor y central no debe ser superior a 10 metros. Utilizar cables con 2,5 mm². Utilizar cables con doble aislamiento (cables con vaina) hasta muy cerca de los bornes, especialmente por el cable de alimentación (230V). Además es necesario mantener adecuadamente distanciados (por lo menos 2,5 mm en aire) los conductores de baja tensión (230V) y los conductores de baja tensión de seguridad (SELV) o utilizar una vaina adecuada que proporcione aislamiento adicional con un espesor mínimo de 1 mm.

Deutsch ALLGEMEINE HINWEISE FUER DEN INSTALLATEUR UND DEN NUTZER

1. Lesen Sie die **Installierungsanweisungen** sorgfältig durch bevor Sie mit der Installation beginnen. Diese Anweisungen an einem leicht zugänglichen Ort aufbewahren.
2. Verpackungsmaterial des Produkts und/oder der Schaltkreise umweltgerecht entsorgen.
3. Dieses Produkt wurde speziell und ausschließlich für den, in den Unterlagen beschriebenen Zweck, geplant und hergestellt. Jede andere Verwendung, die nicht ausdrücklich angegeben wurde kann die Integrität des Produkts schädigen und/oder eine Gefahrenquelle darstellen. Die nicht fachgerechte Nutzung des Produkts bewirkt die Erlöschung der Garantie. SEA S.p.A. lehnt jegliche Haftung, für unsachgemäße oder andere Nutzung, als die wofür das Produkt bestimmt ist, ab.
4. SEA Produkte entsprechen den folgenden Richtlinien: Maschinenrichtlinie (2006/42/EG und nachträglich geänderten Fassungen), Niederspannungs-Richtlinie (2006/95/EG und nachträglich geänderten Fassungen), EMV (2004/108/EG und nachträglich geänderten Fassungen). Installation gemäß Standard EN12453 und EN12445 durchführen.
5. Installieren Sie das Gerät nicht in explosionsgefährdeten Umgebungen, das Vorhandensein von brennbaren Gasen oder Dämpfen stellt ein ernstes Sicherheitsrisiko dar.
6. SEA S.p.A. ist nicht für die Nichtbeachtung der Guten Technik bei der Herstellung von zu motorisierenden Toren und für deren eventuellen Verformungen, die während des Gebrauchs auftreten könnten, haftbar.
7. Vor allen Eingriffen, das Gerät ausschalten und die Batterien trennen. Sicherstellen, dass die Erdung fachgerecht hergestellt wurde und die Metallteile des Tores daran anschließen.
8. Für jede Anlage wird empfohlen, mindestens ein Blinklicht zu montieren und ein Warnschild auf der Torstruktur anzubringen.
9. SEA S.p.A. übernimmt keine Haftung für Sicherheit und reibungslosen Betrieb des Antriebs, bei Verwendung von Komponenten, die nicht von der SEA Produktion stammen.
10. Für die Wartung nur SEA Originalteile verwenden.
11. Keinerlei Änderungen auf Komponenten der Automation vornehmen.
12. Der Installateur muss den Nutzer des Antriebs über den manuellen Betrieb des Systems im Notfall unterrichten und ihm, das, dem Produkt beiliegende, Handbuch übergeben.
13. Der Aufenthalt von Kindern oder Erwachsenen in der Nähe des Tores während seines Betriebes ist nicht gestattet. Die Anlage darf nicht von Kindern, Personen mit eingeschränkten körperlichen, geistigen oder sensorischen Fähigkeiten oder von Menschen ohne notwendige Erfahrung oder Anweisungen benutzt werden. Fernbedienungen oder andere Impulsgeber außerhalb der Reichweite von Kindern halten, um die versehentliche Aktivierung der Anlage zu verhindern.
14. Die Durchfahrt zwischen den Flügeln ist nur bei vollständig geöffnetem Tor zulässig.
15. Sämtliche Wartungs- und Reparaturarbeiten oder periodische Kontrollen, müssen von qualifiziertem Fachpersonal durchgeführt werden. Der Endverbraucher muss davon absehen eigenständig Reparaturen oder Eingriffe jeder Art an der Anlage durchzuführen und muss sich ausschließlich an qualifiziertes SEA Fachpersonal wenden. Der Endverbraucher darf nur die manuelle Notfunktion durchführen.
16. Die maximale Länge der Stromkabel zwischen Steuerung und Motoren ist 10 Meter. Verwenden Sie Kabel mit 2,5 mm² Querschnitt und Doppelisolierung (Kabelmantel) in der unmittelbaren Nähe von Klemmen, insbesondere für das Speisungskabel (230V). Die Speisungskabel (230V) und die Sicherheits-Niederspannungskabel (SELV) müssen in einem Abstand von mindestens 2,5 mm gehalten werden, oder eine geeignete Hülse von 1mm Dicke, für eine zusätzliche Isolierung verwenden..



Dichiarazione di conformità
Declaration of Conformity

La SEA S.p.A. dichiara che, con l'installazione degli adeguati dispositivi di sicurezza e di filtraggio disturbi, i prodotti:

SEA S.p.A. declares that by installing the appropriate safety equipment and noise filtering the products:

Descrizione / Description	Modello / Model	Marca / Trademark
Half Tank 270 AC (e tutti i suoi derivati/ <i>and all its by-products</i>)	10401026	SEA
Half Tank 390 AC (e tutti i suoi derivati/ <i>and all its by-products</i>)	10501036	SEA
Mini Tank 270 AC (e tutti i suoi derivati/ <i>and all its by-products</i>)	10103505	SEA

sono costruiti per essere incorporati in una macchina o per essere assemblati con altri macchinari per costruire una macchina ai sensi della Direttiva 2006/42/CE:

are built to be integrated into a machine or to be assembled with other machinery to create a machine under the provisions of Directive 2006/42/CE:

sono conformi ai requisiti essenziali di sicurezza relativi al prodotto entro il campo di applicabilità delle Direttive Comunitarie 2006/95/CE e 2004/108/CE.

are conforming to the essential safety requirements related to the product within the field of applicability of the Community Directives 2006/95/CE and 2004/108/CE.

COSTRUTTORE o RAPPRESENTANTE AUTORIZZATO:
MANUFACTURER or AUTHORIZED REPRESENTATIVE:

SEAS.p.A.
DIREZIONE E STABILIMENTO:
Zona industriale 64020 S.ATTO Teramo - (ITALY)
Tel. +39 0861 588341 r.a. Fax +39 0861 588344
[Http://www.seateam.com](http://www.seateam.com)

I test sul prodotto sono stati effettuati in configurazione standard e in riferimento alle norme specifiche per la sua classe d'utilizzo.

The products have been tested in standard configuration and with reference to the special norms concerning the classe of use.

(Luogo, data di emissione)
(Place, date of issue)
Teramo, 23/11/2012

L'Amministratore
The Administrator
Ennio Di Saverio



Questo articolo è stato prodotto seguendo rigide procedure di lavorazione ed è stato testato singolarmente al fine di garantire i più alti livelli qualitativi e la vostra soddisfazione. Vi ringraziamo per aver scelto SEA.

This item has been produced following strict production procedures and has been singularly tested for the highest quality levels and for your complete satisfaction. Thanks for choosing SEA.

Cet article a été produit suivant des procédures d'usinage strictes et il a singulièrement été testé afin de garantir les plus hauts niveaux de qualité pour votre satisfaction. Nous vous remercions d'avoir choisi SEA.

Este artículo ha sido producido siguiendo rigidos procedimientos de elaboración y ha sido probando singolarmente a fin de garantizar los mas altos niveles de calidad y vuestra satisfaccion. Le agradecemos por haber escogito SEA.

CERTIFICATO DI ESTENSIONE GARANZIA
CERTIFICATE OF WARRANTY EXTENTION

n.

PRODOTTO/ PRODUCT

- Modello/Model _____
- Matricola n. /Serial Number _____
- Data di acquisto/Date of order _____
- Data di installazione/Date of installation _____

Centrale/Control unit	SEA <input type="checkbox"/>	Altri/Others	<input type="checkbox"/>
Fotocellule/Photocells	SEA <input type="checkbox"/>	Altri/Others	<input type="checkbox"/>
RX - TX	SEA <input type="checkbox"/>	Altri/Others	<input type="checkbox"/>
Altri accessori /Other accessories	SEA <input type="checkbox"/>	Altri/Others	<input type="checkbox"/>

UTENTE/Customer

Nome e Cognome _____
First Name and Family Name _____
Indirizzo/Address _____

INSTALLATORE/Installer

Ragione sociale/Company Name _____
Nome e Cognome/First and Family Name _____
Indirizzo/Address _____

INSTALLATORE/INSTALLER

Firma per il trattamento dei dati personali 196/2003
Agreement of law No. 196/2003 (Privacy Code)

Copia da restituire
Copy to be returned

Firma e Timbro
Sign and Stamp _____

N.B: L'estensione della garanzia legale di 12 mesi a 24 mesi e 36 mesi è valida solo se il presente modulo viene rispedito per posta o fax a SEA S.p.A. entro 15gg dalla data di acquisto. Allegare relativa fattura dacquisto.

Note: The extension of the legal standard warranty of 12 months to 24 months and to 36 months, is valid only if the present form is returned by mail or fax to SEA S.p.A within 15days from the date of purchase. Attach customer invoice.



SEA[®]
Sistemi Elettronici
di Apertura Porte e Cancelli
International registered trademark n. 804888

SEA S.p.A. - Zona Industriale San Atto- 64020 Teramo (Italy)
Phone +39 0861 588341- Fax +39 0861588344
www.seateam.com - info@seateam.com



SEA S.p.A.
Zona Ind. S.Atto 64020 TERAMO Italy
Tel. +39.0861.588341 - Fax+39.0861.588344

e-mail: seacom@seateam.com
WEB SITE : www.seateam.com