

Accesorios Incluidos



Tarjeta electrónica y dos (2) controles remoto



Caja metálica para accionamiento del sistema de manual y pulsador

Características Técnicas

Modelo	Torque	Carga máxima	Potencia	R.P.M	Altura máxima	Freno	Diámetro de eje	Diámetro de cilindro
TIGER T210	210 Nm	210 Kg	650 W	9.5	6 m	Eléctrico	75 mm	240 mm
TIGER T420	420 Nm	420 Kg	1290 W	9.5	6 m	Eléctrico	75 mm	240 mm
TIGER F260	260 Nm	260 Kg	800 W	10	6 m	Eléctrico	60 mm	200 mm
TIGER F360	360 Nm	360 Kg	1198 W	10	6 m	Eléctrico	60 mm	200 mm

Dimensiones (mm) TIGER F260 / F360

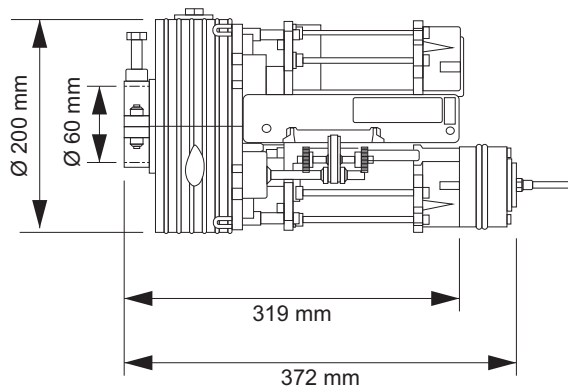

Dimensiones (mm) TIGER T210 / T420

